

Adjustable Frequency Drives and HVAC Systems An Application Guide

INTRODUCTION

All buildings pose the same problem: how to heat or cool the air inside to create a more comfortable environment for the occupants. In small buildings such as a house, this task is easily handled with air conditioners and heaters. Larger buildings such as offices, hotels, or factories pose a more difficult problem due to their size and complexity.

The most typical heating and cooling solution is to move air around the building while modifying the air temperature by passing the air over heated or cooled water as required. Such a system consists of a water stage and an air stage. Figure 1 illustrates the basic concept of such a system.

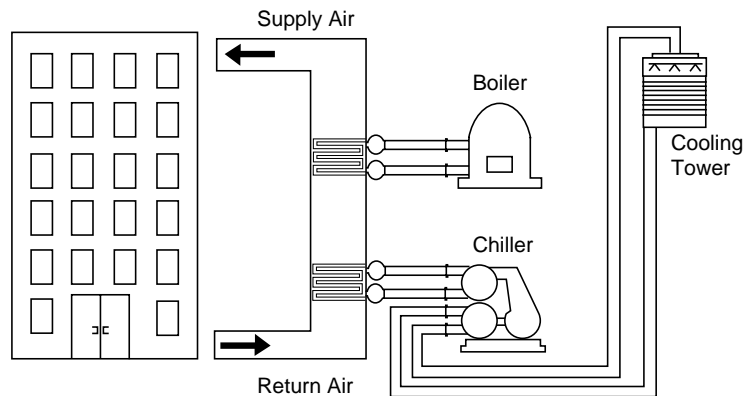

Figure 1 Heating, Ventilation, and Air Conditioning (HVAC) System

Water Stage

The water stage is the first step of temperature control. Air is not an efficient medium to heat or cool directly. The most efficient and inexpensive medium that we can heat or cool is water. This water can then be used to change the temperature of the passing air.

Heating water is very simple. Municipally-supplied water is pumped into a boiler where it is exposed to heat from oil, gas, coal, or electricity. The hot water is then pumped out into coils that are used for heating the building air.

Cooling water is a little more complex and revolves around a device called a chiller. A chiller consists of a compressor, a condenser, and an evaporator. Two separate water circuits exist in the chiller; one circuit removing heat from the building air and one circuit dissipating that heat via a cooling tower.

Air Stage

The air stage is the medium for heat exchange in the building spaces. Air is constantly circulated through a building to either bring in or carry away heat as required. If the air needs to be cooled, it is directed over coils of cool water. If the air needs to be heated, it flows over coils of hot water. Outside air is also vented in at times to save chiller energy when the outside air temperature is cool enough to help the system.

HVAC SYSTEM ARCHITECTURE

Single Zone System

Every building, when designed, presents a different type of heating and cooling challenge. Correspondingly, a wide range of HVAC solutions have been developed over the years, particularly for large buildings.

The most simple and common of all HVAC designs is the single duct/single zone system, much like the system shown in Figure 2. This system is designed to supply air at a single temperature to a single large area (or zone) of a building. Some buildings are designed with the entire structure as a single zone. Although this system is simple and inexpensive to construct, the lack of control makes it difficult to keep all of the occupants comfortable, especially if parts of the building are affected differently by wind or sunlight. This type of system also wastes energy when heating or cooling areas that do not require it.

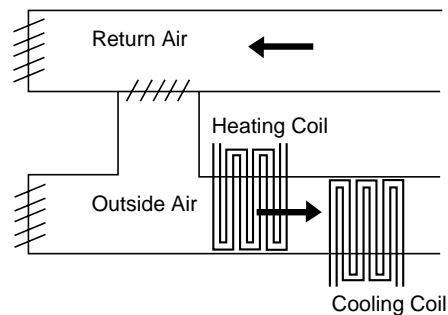

Figure 2 Single-Zone System

The most flexible part of a single zone system is the selectable recirculation of building air. Selectable air recirculation is common to most HVAC architectures and is part of all the systems discussed here. In this design, outside air is only used if its temperature will move the building temperature in the desired direction, warmer or colder. If the outside air is not at a useful temperature, the outside air dampers may be closed and the intermix damper opened to allow the building air to recirculate. However, the outside air dampers do not close all the way. Some outside air must be brought in for health reasons. It is a general requirement that 20 cubic feet per minute of air be brought in for each occupant at all times.

Terminal Re-heat System

A slightly more sophisticated system is called terminal re-heat (see Figure 3). These systems send out uniformly cool or hot air to multiple zones in a building. Each zone is equipped with a thermostat and a heating coil. When a zone's thermostat calls for warmer air, a heating coil is activated to provide the required heat.

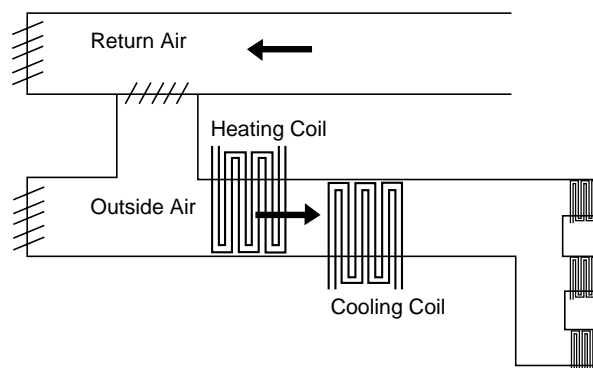

Figure 3 Terminal Reheat System

Hot Deck/Cold Deck System

Many large zone systems use air directed over cooling coils in one duct as cool air, and air directed over heating coils in another duct as hot air for ventilation. These sections are usually referred to as the hot deck and the cold deck. As in the previous cases, this system makes use of outside air when appropriate. Figure 4 shows the typical configuration for such a system. This approach is also used for multiple zone systems. By paralleling several of the systems shown, from common outside air ducts, hot and cold deck systems can operate independently for each zone.

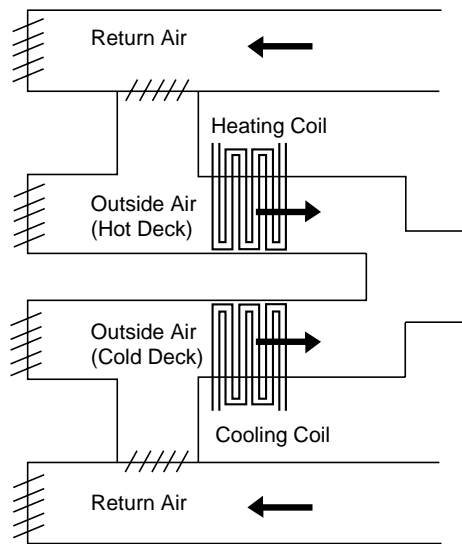

Figure 4 Hot Deck/Cold Deck System

Dual Duct System

More cooling efficiency can be gained by using dual duct systems (see Figure 5). In a dual duct system, the hot and cold deck air is brought to each building zone independently. Each zone has a thermostat-controlled mixing box. This box feeds the proper combination of hot and cold air to reach the thermostat's set point for the zone.

In better systems, a control scheme detects periods where no zones are calling for either hot or cold air and shuts down the appropriate system. In the morning, for example, it is unlikely that cold air will be required as the building heats up. In that instance, the cold deck coil and fan would be shut down to conserve energy.

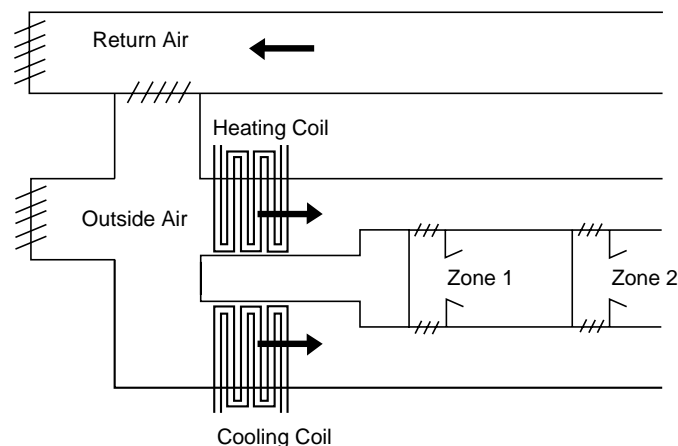

Figure 5 Dual Duct System

VAV Systems

The most sophisticated systems are variable air volume (VAV) systems, as shown in Figure 6. In VAV systems, a central unit supplies cooled or heated air at constant, controllable temperatures to VAV boxes for each zone.

By opening and closing vanes in the airflow, these boxes vary the quantity rather than the temperature of the air, resulting in the desired amount of cooling or heating in the zone. In structures where zoned air conditioning is required, VAV is the most common choice.

VAV is also the most energy efficient of the mechanical control systems. A static pressure sensor in the main duct detects changes in the duct pressure caused by the opening and closing of the zone boxes. This pressure reading is used in a loop control scheme with vanes or dampers on the supply fan to maintain a constant static pressure in the duct. When less air is required to maintain the pressure (i.e., the zone boxes are closed), the fan is unloaded and consumes less energy.

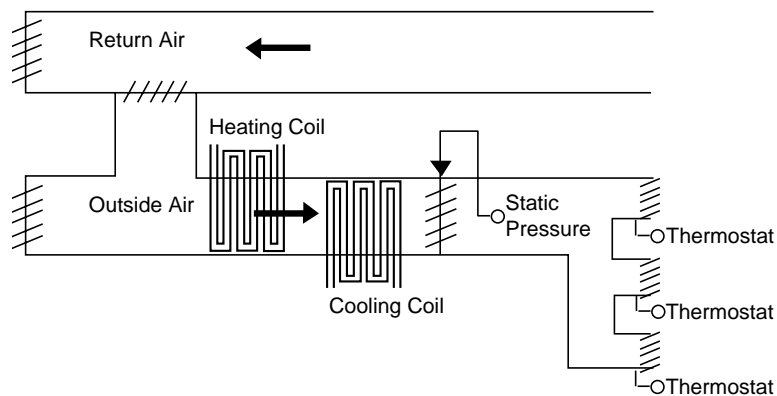

Figure 6 VAV System

COOLING SYSTEMS

Providing cooling is the most complex part of HVAC systems. The two primary components used to achieve this are chillers and cooling towers.

Chillers

A chiller is the central means of heat exchange between the inside and outside of a building (refer to Figure 7). The chiller serves two basic functions: to cool the air in a building and to provide dehumidification.

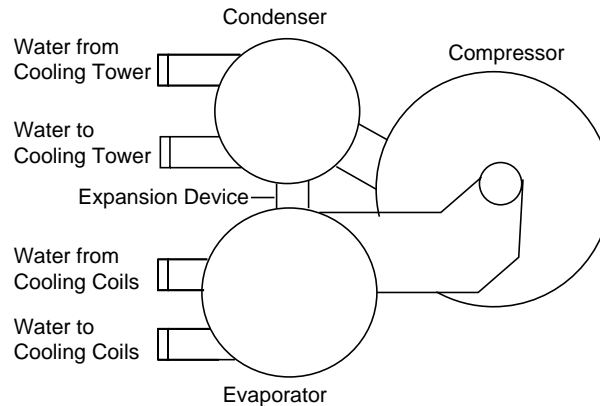

Figure 7 Chiller

Water enters the evaporator and the condenser through external piping. Tubing inside the piping is surrounded by a chiller medium, which is a compressible gas such as freon. As the water circulates within the tubing, heat is transferred between the water and the chiller medium.

The chiller medium is subjected to two stages of pressurization. First, the medium is fed into the condenser at high pressure by the compressor. When the medium is compressed, its temperature increases. The chiller medium then leaves the condenser through an expansion device that suddenly lowers the medium's pressure before it enters the evaporator. When the medium is thus expanded, its temperature decreases. The change in pressurization between these two stages is the key to the cooling provided by the chiller.

Heat is removed from the building air as the air passes over coils in the air ducts through which chilled water is flowing. This water flows into the evaporator where the heat is transferred to the chiller medium. The chiller medium is pressurized in the compressor, then transfers the resultant heat energy, which is a combination of the building heat picked up in the evaporator and the effects of compression, into the water in the condenser circuit. The condenser water is pumped into a cooling tower where the heat delivered from the compressor is dissipated into the outside air.

In effect, the evaporator acts as a device to absorb heat from the building air while the condenser acts as a device to remove that heat from the building once it is picked up.

Cooling Towers

The job of the cooling tower is to radiate the heat of the building. Located on the outside of a building, the tower removes heat from the condenser water as the condenser water removes heat from the chiller. See Figure 8.

Water in a cooling tower is cooled by evaporation. Every pound of water that a cooling tower evaporates removes 1,000 BTU from the system. This lowers the temperature of 1,000 pounds of water by 1 degree Fahrenheit.

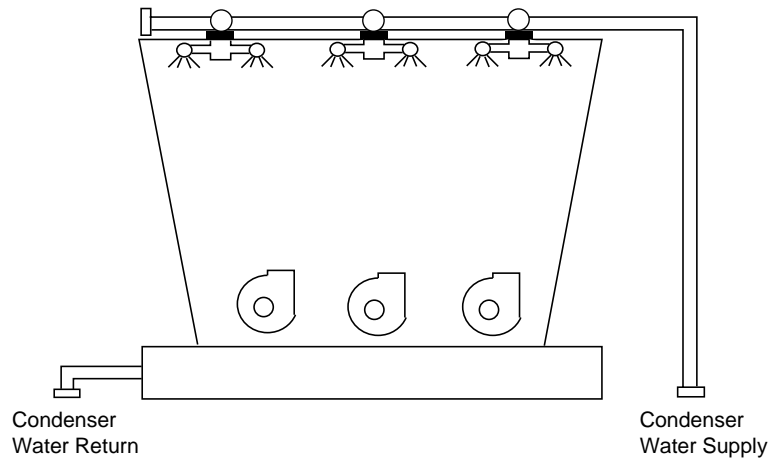

Figure 8 Cooling Tower

The condenser water is released from the top of the tower in a fine spray. The finer the spray, the more surface area is available for evaporation. As the cooling tower fans blow air through the spray, the air carries away some of the heated water vapor, further aiding the evaporation process. Water in the tower cools by about 10 degrees Fahrenheit and is circulated back to the chiller to be heated again by the condenser.

The efficiency of evaporation in a cooling tower at any given time is determined by a combination of outside air temperature and humidity. A special type of scale, called wet-bulb temperature, was created for controlling cooling towers. Wet-bulb temperature is determined by a thermometer enclosed in a water-soaked wick. A tower removes heat better on a cool, dry day than on a hot, humid day. This reading is therefore used to control most cooling towers.

Dehumidifying

Warm air contains more moisture than cool air. The more moisture in the air, the more slowly perspiration evaporates. Since perspiration evaporation is an important mechanism for cooling the human body, high humidity increases discomfort during warm weather. Good HVAC systems not only cool the building, but also remove excess moisture.

Condensation dehumidification is the process most often used in HVAC systems to remove excess moisture from the air. When warm, moist air passes over a cooling coil, its temperature can fall to a point where the air can no longer hold all the moisture it contains. The moisture then condenses on the coil as droplets which may be drained away. Typically this task is accomplished by the coils using chilled water to cool the building and condensation is simply drained off of these coils as it builds.

PUMPS AND FANS

In order for air and water to be used to control the temperature of a building, there must be a way to move them around in the building. Pumps and fans are similar kinetic devices and both use the same principles to move water and air.

Centrifugal Pumps

A centrifugal pump consists of a rotating impeller inside of a specially shaped shell. As the impeller rotates, liquid is taken in at the axis of the impeller and forced out along vanes to its tips. The liquid moves faster at the tips of the impeller than at the axis. The fluid is then gathered in a specially shaped diffusing section called a volute, where it is discharged at high pressure.

Pumping Systems

Pumping systems are designed to increase both the flow and pressure of a liquid. In tall buildings, the pressure at which water leaves pumps is critical. Think of a water pipe in a building as a standing column of water. In order to move the water from the bottom up, the water at the bottom has to be pushed up with enough force to overcome the weight of the water above and the friction of the piping system that the water is flowing in. This force is referred to as the total dynamic head of the system.

All of the water systems in a building must be designed to overcome the dynamic head of the system and provide the proper flow and pressure at the water's destination. The water systems in a building include condenser water pumps, chilled water pumps, HVAC hot water pumps, and domestic water pumps.

Municipal water systems are often designed as low-pressure systems. Lower pressure in the system means that there is less stress on pipes and fittings, leading to longer life and lower maintenance costs. Unfortunately, this means that most buildings get water at too low of a pressure.

If a municipal water system only delivers enough pressure to overcome the dynamic head of a two-story building, any building over that height needs booster pumps to increase the pressure after it enters the building.

Booster pumps are also required for domestic and HVAC hot water systems. Nearly all buildings have their boilers located in the basement. After the water is heated in the boiler, pumps must be used to give the heated water sufficient pressure to go where needed in the building.

Centrifugal Fans

Traditional, three-bladed, "propeller-style" fans are not very common. They are often noisy and inefficient. Centrifugal fans are classified according to blade arrangement such as radial, airfoil, and forward curved. Widely used in larger HVAC systems, especially in industry, centrifugal fans move considerable volumes of air over a wide range of pressures.

Centrifugals have a rotating cylinder (impeller) mounted inside a scroll-type housing which somewhat resembles a snail's shell. These fans have scoop-like blades that collect air and throw it against the inside of the housing to create the desired air stream for efficient cooling.

Fan System Design

Fans are located in systems according to their intended functions. Supply fans, for example, bring in air and must be placed so that air flows through them into the air ducts. Exhaust fans belong at the other end of the air stream. Fans that supply several spaces at once are centrally located. Otherwise, flow rates to different spaces vary and the fan operates inefficiently, wasting energy.

In designing systems, engineers must take into account the temperature of the air that the fan moves. Cool air is denser than hot air. This affects fan performance and efficiency.

The way that air flows toward a fan is an important factor in determining its efficiency. If the entire air stream moves at uniform speed, for example, all portions of the fan do equal work and efficiency is maximized. If air speed is uneven, the work is unequally distributed, causing a lower operating efficiency. This problem is often solved by placing a length of straight duct at the fan intake. The duct smooths the airflow before the air enters the fan. Proper design of duct work is an art in itself. If this is not done right, the system will have very poor efficiency and could also have significant audible noise problems.

Air-conditioning fans are usually arranged in long, rectangular ducts. Made from galvanized steel, the ducts may be attached to the ceilings, walls, or floors of the conditioned space. Ducts often contain metal vanes that direct the airflow to increase system efficiency. Room air inlets and outlets are customarily rectangular in shape and fitted with a metal grill, which often has dampers that open and close to control flow.

ADJUSTABLE FREQUENCY DRIVES

An adjustable frequency drive is an electronic device that changes the speed of a motor's rotation by changing the frequency of the power being fed to the motor.

The relationship between a motor's speed and the frequency of the power fed to the motor is linear. For instance, a motor that is designed to turn at 1,800 revolutions per minute (RPM) when connected to a standard 60 Hz power supply, will turn at 900 RPM when connected to an adjustable frequency drive supplying 30 Hz of power.

Use in HVAC Systems

Pump and fan systems are generally designed to use a full-speed, non-reversing motor to drive a mechanical air or water mover. The output of these systems is controlled by mechanically constricting the flow with throttling valves or damping vanes.

Although constricting water or airflow reduces the load on the motor and therefore the power required to run the motor, flow constriction is not very efficient. Running a system this way is like driving a car with the accelerator pressed to the floor while controlling speed with the brake.

An adjustable frequency drive, on the other hand, allows precise control of motor output. In the case of centrifugal fans and pumps, there is a significant reduction in the power required to handle the load. This power reduction is due to the fact that most pumps and all fans are variable torque loads.

Variable Torque Loads

In a variable torque load, the torque required to drive the load changes according to the speed. As the speed of a load is reduced, the torque required to drive it is decreased as a square of the speed. For example, at 50 percent speed only 25 percent of the torque required at full speed is needed to turn the load, as shown in Figure 9.

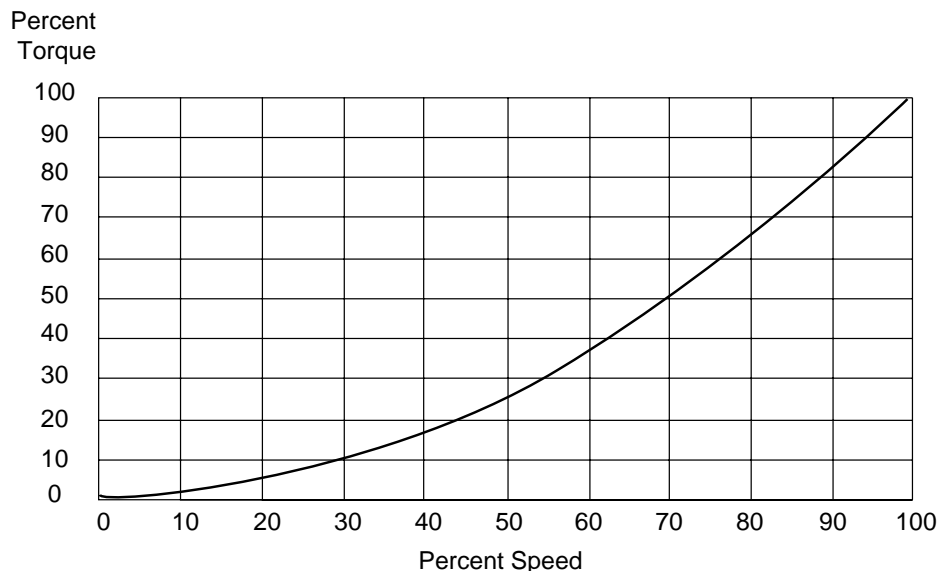

Figure 9 Variable Torque Loads

Fans and pumps are designed to make air or water flow. As the rate of flow increases, the air or water has a greater change in speed put into it by the fan or pump, increasing its inertia. In addition to the inertia change, increased flow means increased friction from the pipes or ducts. An increase in friction requires more force (or torque) to make the air or water flow at that rate.

The Affinity Laws

The effects that reduced speed has on a variable torque fan or pump are summarized by a set of rules known as the Affinity Laws. The basic interpretation of these laws is quite simple:

1. Flow produced by the device is proportional to the motor speed.
2. Pressure produced by the device is proportional to the motor speed squared.
3. Horsepower required by the device is proportional to the motor speed cubed.

For instance, an adjustable frequency drive running a variable torque load at 50 percent speed needs to deliver only 12.5 percent of the horsepower required to run it at 100 percent speed. The reduction of horsepower means that it costs less to run that motor. When these savings are applied over the yearly hours of operation, significant savings accumulate.

Percent
Flow, HP, Pressure

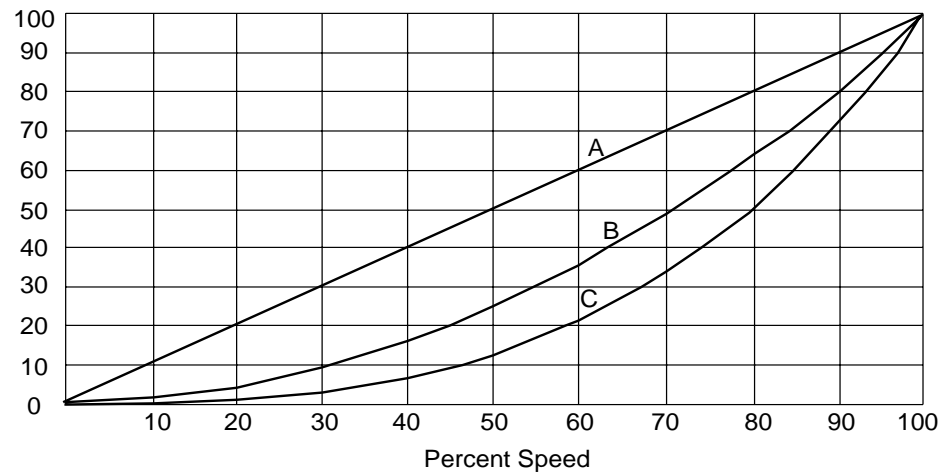

A: Flow
B: Pressure
C: Horsepower

Figure 10 The Affinity Laws

As always, you don't get something for nothing. While the first and third affinity laws allow us to save energy at a reduced speed, the second affinity law shows the effect that this speed reduction has on the pressure that the pump or fan delivers. While this is a significant consideration in most pumping systems, pressure is not as critical in most fan applications. If proper care is taken in engineering the application, adjustable frequency drives can provide significant energy savings for many different installations.

PUMP AND FAN CURVES

As the second affinity law shows, the amount of pressure that a system can deliver is reduced when its speed is reduced. While the affinity law shows a general square relationship, the exact result depends on the specific mechanical design of the fan or pump system in question.

All fan and pump manufacturers publish performance curves for their products. These curves show what pressures a system produces at reduced speeds. Whenever reduced speed operation is considered, these curves need to be examined in order to determine the speeds at which the fan or pump can run and still make air or water flow.

Consider a pump that produces 140 pounds per square inch (PSI) of pressure when run at full speed. The system that the pump is connected to has a static system pressure of 100 PSI. When variable speed operation is considered for that pump, the pump needs to rotate at a speed that yields at least 100 PSI of pressure or the water will not move. The pump won't even generate enough pressure to overcome the weight of the water above it. In order to determine this minimum speed, the pump curve must be redrawn for variable speed operation using the affinity laws.

Reading standard pump or fan curves is fairly straightforward. All of the curves consist of a simple graph with flow rates along the horizontal axis and pressures along the vertical axis. Manufacturers may also add additional scales and curves to the graph to show how efficient the pump is at certain points along the curve and how much brake horsepower is required to drive the pump at those points. More complex publications show curves for multiple impeller or blower sizes on the same graph.

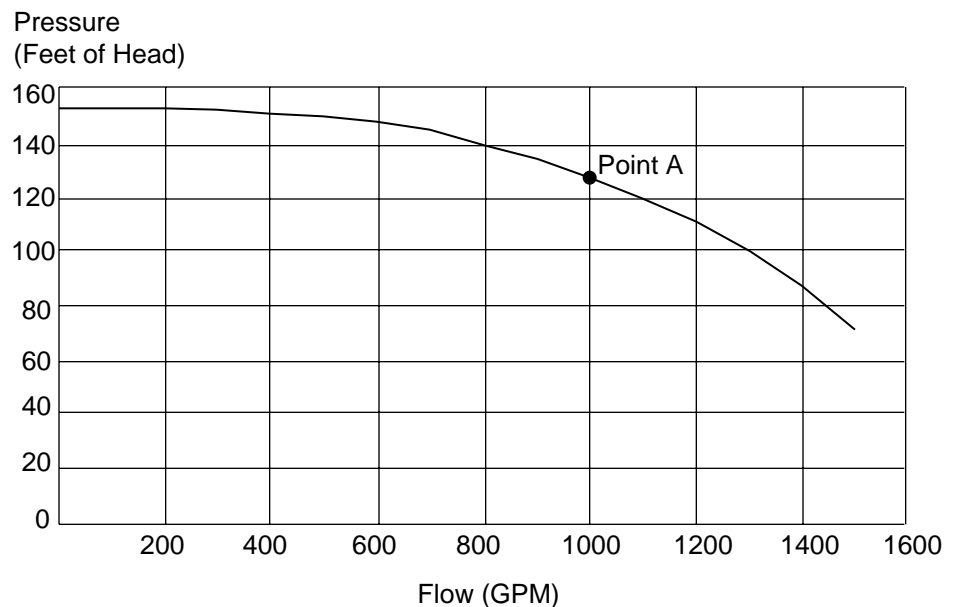

Figure 11 Typical Pump Curve

When a pump or fan is connected to a system, the static and dynamic pressures of that system dictate a natural operating point for that pump or fan. For example, on the pump curve shown in Figure 11, if the system pressures add to 130 PSI, the natural operating point of the system is Point A, at 1,000 gallons per minute (GPM) and 130 PSI.

If a system operator wants to generate less than the 1,000 GPM of the natural operating point, a throttling valve is commonly used. As the valve is closed, the operating point moves along the pump curve to the left, increasing pressure as the flow is reduced. As the valve is opened up again, the operating point moves back along the pump curve to the right.

Adjustable Speed Drives and Pump/Fan Curves

In order to understand the effect that an adjustable frequency drive has on these curves, we need to apply the affinity laws. The curves provided by manufacturers are always based on the operation of the pump or fan at full RPM. Using the first and second affinity laws, a new set of curves can be generated for lower RPMs by simply replotting each point on the curve using the following formulas:

$$\text{New Flow Coordinate} = \text{Original Flow Coordinate} \times \left(\frac{\text{New RPM}}{\text{Original RPM}} \right)$$

$$\text{New Pressure Coordinate} = \text{Original Pressure Coordinate} \times \left(\frac{\text{New RPM}}{\text{Original RPM}} \right)^2$$

Figure 12 shows a typical 60 Hz pump curve with new curves plotted for 50 Hz, 40 Hz, and 30 Hz operation as well.

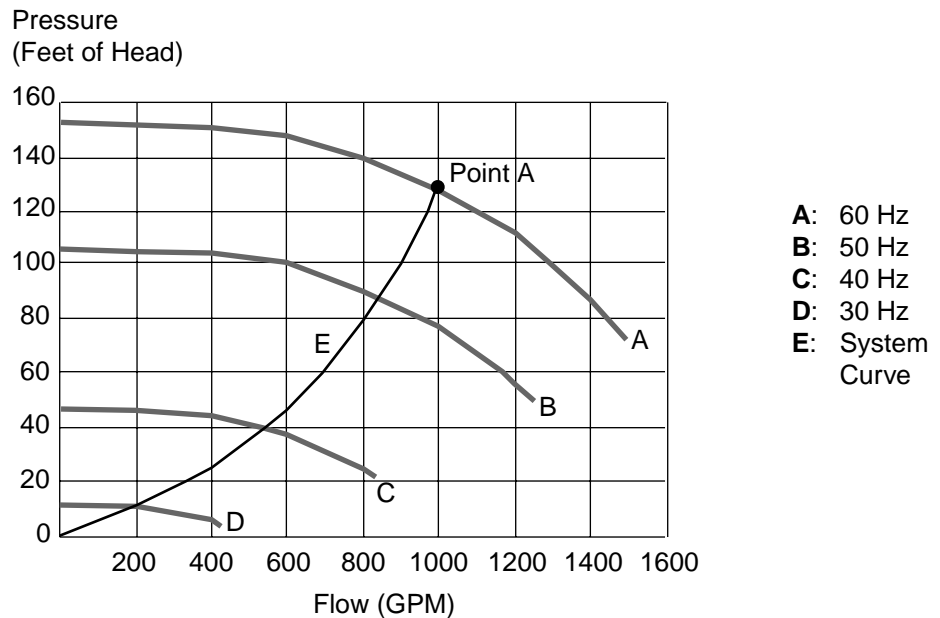

Figure 12 Typical Pump Curve

The same set of formulas allows you to calculate the new position of the operating point for each curve. The curve made up of these operating points is called a system curve. The adjustable frequency drive is only able to reach the pressures and flows that lie along this system curve. Although it is possible to use an adjustable frequency drive and throttling valve in combination to reach any point between the system curve and the original pump curve, such an application is rarely used.

CALCULATING ENERGY SAVINGS

While the theoretical models presented above are quite accurate, when calculating actual energy savings, it is best to take real world efficiencies into account. There are several computer programs available from drive manufacturers that provide more “real world” models of the potential energy savings that adjustable frequency drives yield. Square D has produced software that is based on the “real-world” performance models generated by the Electrical Power Research Institute (EPRI).

VAV Fan Systems

Variable air volume fan systems have become quite typical in HVAC systems over the past 10 years. A VAV system is designed to maintain a constant static pressure in the air ducts, regardless of the changing demands of the building.

Supply and return air fans are connected to the duct work and cycled on and off according to the operating hours of the building. During operation, static pressure sensors in the ducts transmit a signal back to the fans. Inlet vanes or outlet dampers (basically giant louvers) open or close in order to provide the airflow that maintains the desired pressure in the duct.

Adjustable frequency drives can replace these vanes, reacting to the same static pressure and control signals being used now. The drive provides the same amount of airflow into the ducts while consuming substantially less energy. The data shown in Figure 13 indicates the difference that an adjustable frequency drive can make in power consumption.

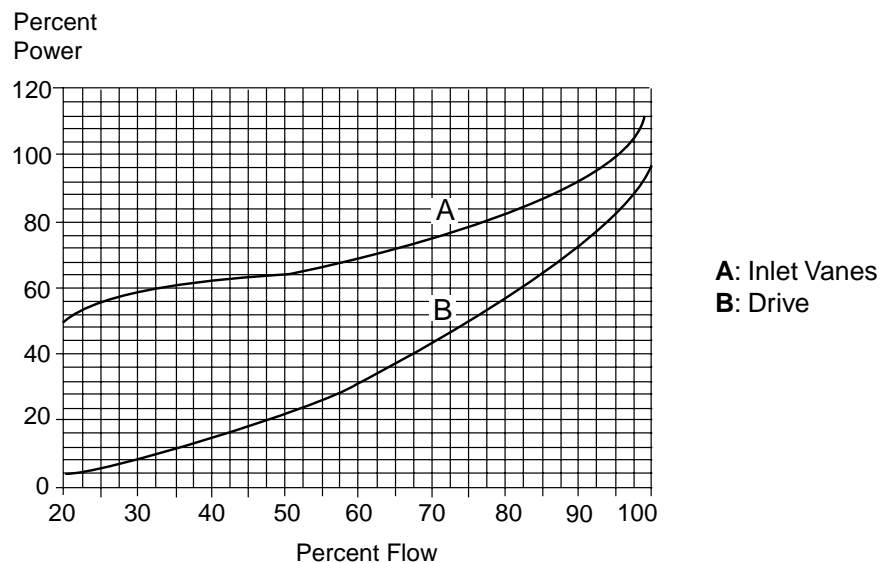

Figure 13 Fan Performance

Based on input of the fan horsepower, motor efficiency, vane type, utility rate, and usage profile, software can calculate the potential annual savings available to the customer. The simple payback period can then be calculated from this data.

It is important to note that the estimated savings in these calculations are based on a comparison of vane and damper systems versus adjustable frequency drive systems in new installations. In retrofit applications, the difference between inlet guide vanes and outlet dampers is critical. In the case of outlet dampers, these savings are only valid if the existing dampers are physically removed from the system. If the dampers are left in place, but locked fully open, they will still interfere with airflow and impede system efficiency, resulting in a slight reduction of energy savings. Inlet vanes, on the other hand, should always be left in place. An inlet vane controls airflow by directing the air into the fan. If these vanes are removed, the fan's operating characteristics will be significantly altered. Instead of removing the inlet vanes, they should instead be adjusted to find their optimum operating point and locked in place there.

Throttle Valve Controlled Pumping Systems

In some pumping systems, the output of a pump is more than the system requires. This can be the result of either an original over design, or seasonal and daily demand variations. In both of these cases, some sort of throttling valve is used to constrict the output of the pump.

Replacing this valve with an adjustable frequency drive allows for low-speed operation and produces the resultant energy savings.

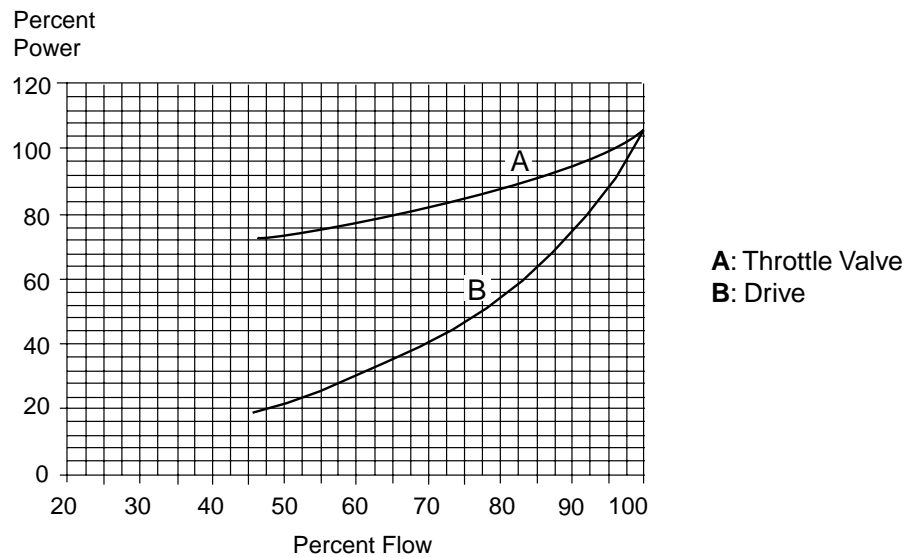

Figure 14 Pump Performance

Based on the input of the pump horsepower, motor efficiency, utility rate, and usage profile, software can calculate the potential annual savings available to the customer.

Special care should be taken with discharge pressure when using these pumping systems. As mentioned earlier, there is a reduction in the amount of pressure that can be generated at reduced speeds. This means that in systems with a significant static head on the discharge of the pump, it may not be possible to reduce the speed significantly. On any pumping system, there is a minimum speed at which the

pump cannot generate enough pressure to operate in the system. An analysis of the pumping system, including the original pump and system curves, should be made in any pumping application. In all cases, an engineer experienced in adjustable frequency drives should be consulted to determine the feasibility of applying the drives to that particular pumping system.

OTHER APPLICATIONS

In addition to the basic systems discussed above, there are several other typical building systems that are good candidates for adjustable frequency drive applications. All of the systems below are proven applications where energy can be saved using adjustable frequency drives. The savings in these cases can be calculated based on the affinity laws with real world efficiencies factored in.

Banked Fans

Sometimes buildings are designed with air moving systems that use banks of fans feeding into the same output. As demand changes, the amount of fans on line is changed to adjust the output. Simpler systems also exist where the full output of one fan is all that is ever needed. The fans in these applications are alternated to maximize motor life.

An adjustable frequency drive is an ideal device for this application. Where two fans are available and only one at a time is being used, a drive can be applied to run both at 50 percent speed. This produces the same amount of output while consuming about 14 percent of the power. Keep in mind that the 50 percent operating point is really a theoretical approximation. The exact operating point for this type of application depends on the fan curves and the system using them.

Banked Cooling Tower Fans

Cooling towers typically use banks of fans, each feeding cooling cells. In the cells, the fan moves outside air through a spray of water, allowing heat to dissipate from the water. As demand changes and more heat needs to be removed from the water, the amount of cells on line is changed to adjust the output.

If an adjustable frequency drive is applied to this system, more cells could be used at one time, while reducing the airflow into them. As in the previous example, the reduced motor speed requires less power to run. In addition to the energy savings from the reduced motor speed, the tower becomes more efficient from the increased surface area being used by the additional cells on-line. This results in even greater overall savings for the building.

Parking Garage Exhaust Fans

All parking garages are required to run fans during operating hours to remove the auto exhaust fumes. These systems are typically run at full speed at all times. Because traffic in a parking garage varies over the course of a day, there are significant time periods when the garage does not need the same amount of ventilation as during peak traffic periods.

The real function of the garage ventilation system is to remove carbon monoxide from the air. A gas-sensing system can be installed to monitor carbon monoxide levels in the garage. This information can in turn be used to adjust fan speed with a control system to keep carbon monoxide levels at a minimum. The system allows for operation at lower speeds and saves energy for the user.

