

APOGEE Terminal Box Controller — Electronic Output Owner's Manual

125-1940 Rev. 5, July 2005

Rev. 5, July 2005

NOTICE

The information contained within this document is subject to change without notice and should not be construed as a commitment by Siemens Building Technologies, Inc. Siemens Building Technologies, Inc. assumes no responsibility for any errors that may appear in this document.

All software described in this document is furnished under a license and may be used or copied only in accordance with the terms of such license.

WARNING

This equipment generates, uses, and can radiate radio frequency energy and if not installed and used in accordance with the instructions manual, may cause interference to radio communications. It has been tested and found to comply with the limits for a Class A digital device, pursuant to Part 15 of the FCC rules. These limits are designed to provide reasonable protection against such interference when operated in a commercial environment. Operation of this equipment in a residential area is likely to cause interference in which case users at their own expense will be required to take whatever measures may be required to correct the interference.

SERVICE STATEMENT

Control devices are combined to make a system. Each control device is mechanical in nature and all mechanical components must be regularly serviced to optimize their operation. All Siemens Building Technologies branch offices and authorized distributors offer Technical Support Programs that will ensure your continuous, trouble-free system performance.

For further information, contact your nearest Siemens Building Technologies, Inc. representative.

Copyright 2005 by Siemens Building Technologies, Inc.

TO THE READER

Your feedback is important to us. If you have comments about this manual, please submit them to SBT_technical.editor@siemens.com

CREDITS

APOGEE is a registered trademark of Siemens Building Technologies, Inc.

Insight for Minicomputers is a registered trademark of Siemens Building Technologies, Inc.

Insight for Personal Computers is a registered trademark of Siemens Building Technologies, Inc.

UniTrak™ is a trademark of Siemens Building Technologies, Inc.

Teflon is a registered trademark of DuPont.

Country of Origin: US

Table of Contents

How To Use This Manual	VII
Manual Organization	VII
Manual Conventions.....	VII
Manual Symbols.....	VIII
Datamate Software.....	VIII
Getting Help.....	VIII
Where To Send Comments.....	VIII
Product Overview	1
Introduction.....	1
Ordering Notes	2
Hardware Inputs	3
Hardware Outputs.....	3
Power Wiring	4
Communication Wiring.....	4
Controller LED Indicators.....	4
Temperature Sensors.....	5
Room Temperature Sensor	5
Duct Temperature Sensor	5
Actuators	5
Related Equipment	5
Applications	7
Basic Operation	7
Sequencing Logic (optional).....	7
Control Temperature Setpoints	7
Day/Night Mode.....	7
Night Mode Override Switch.....	7
Control Loops	7
Calibration	7
Damper Status Operation.....	8
Fail-safe Operation.....	8
Secure Mode Operation	8
Heating and Cooling Switchover	8
Modulate Damper During Heating Mode (optional)	8
Hot Water Reheat.....	8
Electric Reheat	9
Notes	9
Application 2020/2120 VAV Cooling Only	10
Overview.....	10
Application 2021/2121 VAV Cooling or Heating	11

Overview.....	11
Application 2022/2122 VAV with Electric Reheat or Baseboard Radiation	12
Overview.....	12
Baseboard Radiation.....	13
Electric Heat Interlock	13
Application 2023/2123 VAV with Hot Water Reheat	14
Overview.....	14
Application 2024/2124 VAV Series Fan Powered with Electric Reheat.....	15
Overview.....	15
Fan Operation	15
Application 2025/2125 VAV Series Fan Powered with Hot Water Reheat.....	16
Overview.....	16
Fan Operation	16
Application 2026/2126 VAV Parallel Fan Powered with Electric Reheat.....	17
Overview.....	17
Fan Operation	17
Application 2027/2127 VAV Parallel Fan Powered with Hot Water Reheat.....	18
Overview.....	18
Fan Operation	18
Application 2091/2191 Slave Mode	19
Overview.....	19
Using Auxiliary Points.....	19
Using the Controller as a Point Extension Device.....	19
Point Database.....	21
Overview.....	21
Glossary	39
Overview.....	39
Index	43

How To Use This Manual

This section covers manual organization, conventions, and symbols used in the manual, and other information that will help you understand and use a Terminal Box Controller — Electronic Output.

Manual Organization

This manual contains the following sections:

- *Chapter 1 Product Overview* describes the hardware components and the accessories that are used with the controller.
- *Chapter 2 Applications* describes the control applications available in the controller.
- *Chapter 3 Point Database* defines the point database descriptors and includes address and applications.
- The *Glossary* describes terms and acronyms.
- The *Index* helps you find information.



Manual Conventions

The following table lists conventions used in this manual.

Convention	Example
Actions that you should perform are specified in boldface font.	Type F for Field panels. Click OK to save changes and close the dialog box.
Error and system messages are displayed in Courier New font.	The message Report Definition successfully renamed appears in the status bar.
New terms appearing for the first time are italicized.	The Open Processor continuously executes a user-defined set of instructions called the <i>control program</i> .

Manual Symbols

The following table lists symbols that are used to draw your attention to important information.

Notation	Symbol	Meaning
CAUTION:		Indicates that equipment damage or loss of data may occur if the user does not follow a procedure as specified.
WARNING:		Indicates that personal injury or loss of life may occur to the user if a procedure is not performed as specified.

Datamate Software

Datamate is a customer software tool for all controller communications. There are two versions: *Datamate Base*, and *Datamate Advanced*. *Datamate Base* works on an IBM-compatible Personal Computer (PC), or a Handheld PC or Pocket PC™ running Windows CE. *Datamate Advanced* works only on an IBM-compatible Personal Computer. With *Datamate*, you can backup, restore, and edit any APOGEE database (but only *Datamate Advanced* allows you to edit points offline). Backing up and restoring a database can be accomplished while connected to any APOGEE field panel, or to the Building Level Network (BLN) or Floor Level Network (FLN) device in question. A modem and telephone lines can also be used. Databases can be saved to a hard or floppy disk and kept for permanent storage or used as backup.

For more information on *Datamate* software, refer to the appropriate user guide based on which version of *Datamate* you are using (Base or Advanced), or contact your local Siemens Building Technologies, Inc. representative.

Getting Help

If at any time you find that you need help with a Terminal Box Controller issue not covered in this manual, contact your local Siemens Building Technologies, Inc. representative.

Where To Send Comments

Your feedback is important to us. If you have comments about this manual, please submit them to SBT_technical.editor@siemens.com.

1

Product Overview

Introduction

The Terminal Box Controller — Electronic Output is the Siemens Building Technologies, Inc. APOGEE Terminal Equipment Controller (TEC) used in pressure independent Variable Air Volume applications (Figure 1-1). It provides Direct Digital Control (DDC) for 16 applications, and can operate independently as a stand-alone DDC room controller or networked with an APOGEE Field Panel. The controller provides all input/output, system, and local communication connections. Hardware consists of the controller and the mounting bracket.

Table 1-1 lists the Terminal Box Controller products that are covered:

Table 1-1. Terminal Box Controller – Electronic Output Applications.

Standard Applications	Secure Mode Applications
2020 VAV Cooling Only	2120 VAV Cooling Only with Secure Mode
2021 VAV Cooling or Heating	2121 VAV Cooling or Heating with Secure Mode
2022 VAV with Electronic Reheat or Baseboard Radiation	2122 VAV with Electronic Reheat or Baseboard Radiation with Secure Mode
2023 VAV with Hot Water Reheat	2123 VAV with Hot Water Reheat with Secure Mode
2024 VAV Series Fan Powered with Electric Reheat	2124 VAV Series Fan Powered with Electric Reheat with Secure Mode
2025 VAV Series Fan Powered with Hot Water Reheat	2125 VAV Series Fan Powered with Hot Water Reheat with Secure Mode
2026 VAV Parallel Fan Powered with Electric Reheat	2126 VAV Parallel Fan Powered with Electric Reheat with Secure Mode
2027 VAV Parallel Fan Powered with Hot Water Reheat	2127 VAV Parallel Fan Powered with Hot Water Reheat with Secure Mode
2091 Slave Mode	2191 Slave Mode with Secure Mode

Ordering Notes

Terminal Box Controller – Electronic Output	540-100
Terminal Box Controller – Electronic Output with Secure Mode	540-100C
Terminal Box Controller—Electronic Output with Autozero Module	540-200
Terminal Box Controller—Electronic Output with Autozero Module with Secure Mode	540-200C

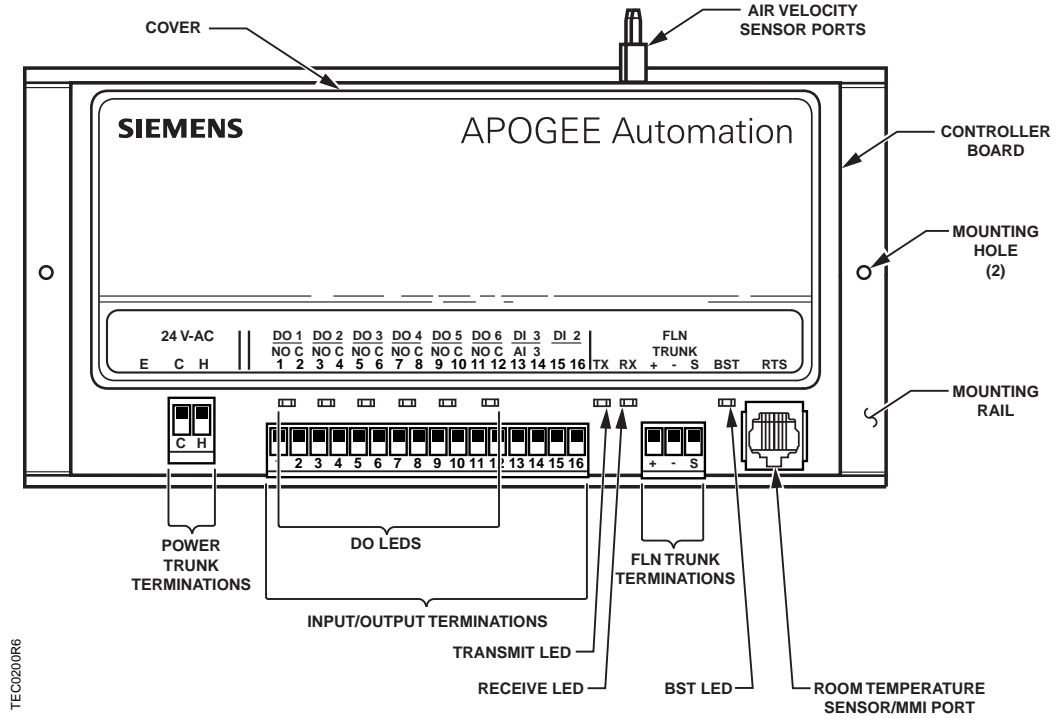

Figure 1-1. Terminal Box Controller — Electronic Output.

Hardware Inputs

Analog

- Air Velocity Sensor (AVS)
- Duct temperature sensor (optional) – Application 2021, 2121
- Room temperature sensor (RTS)
- Room temperature setpoint dial (optional)

Digital

- Night mode override (optional)
- Wall switch (optional)

Hardware Outputs

Analog

- None

Digital

	Application
• Autozero Module (AZM) (optional)	2020, 2021, 2022, 2023, 2120, 2121, 2122, 2123
• Damper Actuator	All
• Fan	2025, 2026, 2027, 2125, 2126, 2127
• First valve actuator (required)	2023, 2123
• Second valve actuator (optional) or AZM (optional)	2023, 2123
• Stage 1 electric reheat; or, 2-position heating valve	2022, 2122
• Stage 1 electric reheat	2024, 2026, 2124, 2126
• Stage 2 electric reheat (optional)	2022, 2024, 2026, 2122, 2124, 2126
• Stage 3 electric reheat (optional)	2022, 2024, 2026, 2122, 2124, 2126
• Valve actuator	2025, 2027, 2125, 2127

Power Wiring

The controller is powered by 24 Vac. Power wiring connects to the two screw terminals on the controller labeled “C” (Common) and “H” (Hot) on the terminal block labeled “24 VAC”. No earth ground connection is required (Figure 1-2).

Communication Wiring

The controller connects to the field panel by means of a Floor Level Network (FLN) trunk. Communication wiring connects to the three screw terminals on the controller labeled “+” (positive), “-” (negative), and “S” (Shield) (Figure 1-3).

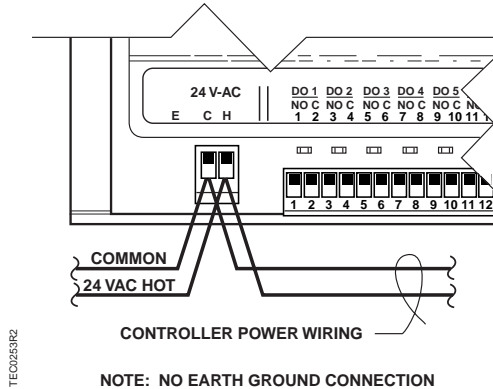

Figure 1-2. Power Wiring.

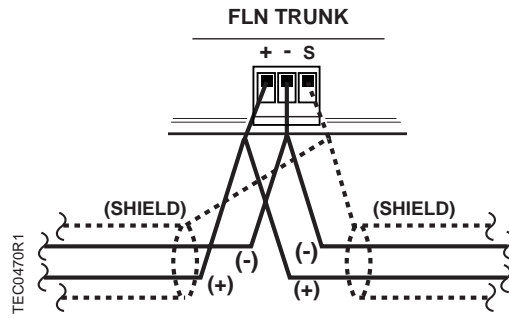

Figure 1-3. Communication Wiring.

Controller LED Indicators

The controller has nine Light Emitting Diode (LED) indicators (Figure 1-1). See Table 1-2.

Table 1-2. Controller LEDs.

LED Type	Label (if present)*	LED Number	Indication
DO	LED 1 - LED 6	1 - 6	Indicates the ON/OFF status of the DO associated with it. A glowing LED indicates that the DO is energized.
Transmit	TX	7	Indicates, when flashing, that the controller is transmitting information to the field panel.
Receive	RX	8	Indicates, when flashing, that the controller is receiving information from the field panel.
BST "Basic Sanity Test"	BST	9	Indicates, when flashing ON and OFF once per second, that the controller is functioning properly.

* Some LED labels and numerals may be hidden by the controller cover.

Temperature Sensors

Temperature sensors used with the Terminal Box Controller – Electronic Output include an electronic room temperature sensor and an optional duct temperature sensor.

Room Temperature Sensor

The Terminal Equipment Controller room temperature sensor connects to the controller by means of a cable terminated at both ends with a six-conductor RJ-11 plug-in connector. See Figure 1-1 for the location of the room temperature sensor/Man Machine Interface (MMI) port.

Duct Temperature Sensor

An optional duct temperature sensor provides duct air temperature sensing inputs to the controller.

For more information about temperature sensors, contact your local Siemens Building Technologies, Inc. representative.

Actuators

Actuators used with the Terminal Box Controller – Electronic Output include electronic damper motors, electronic valve motors, and electronic valve assemblies. These actuators, powered through the controller, position reheat valves or supply air dampers.

Related Equipment

- Autozero Module (optional) 540-200
- Relay Module
- Damper Actuator(s)
- Duct Temperature Sensor (100K Ω) (optional)
- TEC Room Temperature Sensor

Contact your local Siemens Building Technologies, Inc. representative for product numbers and more information.

2

Applications

Basic Operation

The Terminal Box Controller — Electronic Output provides Direct Digital Control (DDC) for Variable Air Volume (VAV) terminal box applications. Temperature control varies with the application. If present, heating can be provided by hot water, up to three stages of electric reheat, or optional baseboard radiation.

Sequencing Logic (optional)

This application has the additional capability to sequence the flow and mechanical heating when heated supply air is available.

Control Temperature Setpoints

The controller maintains a specified temperature setpoint based on Day/Night mode, or the heating/cooling mode, or the setpoint dial (if used).

Day/Night Mode

The controller maintains the specified day setpoint temperature during daytime hours and the specified night setpoint at night.

Night Mode Override Switch

If the RTS has an override switch, it can be used to command the controller into day mode for an adjustable period of time. This only affects a controller in night mode.

Control Loops

Temperature Loop – Heating Loop – Cooling Loop – maintain temperature setpoint by changing the flow setpoint or modulating the heat source (valve/electric heat).

Flow Loop – maintains flow setpoint by modulating the damper actuator.

Calibration

Air Velocity Sensor - Calibration of the controller's internal air velocity sensor is periodically required to maintain accurate air velocity readings. Calibration may be set to take place automatically or manually.

Autozero Module (AZM) – Used when damper cannot be closed and constant airflow is needed.

- For a controller used with an AZM, calibration occurs without closing the damper. Application 2020, 2021, 2022, 2023, 2120, 2121, 2122, 2123.

- For a controller used without an AZM, the damper is briefly commanded closed to get a zero airflow reading and an accurate damper position during calibration. Application 2020, 2021, 2022, 2023, 2120, 2121, 2122, 2123.

Hot Water Valve – Calibration of a hot water valve (if used) is done by briefly commanding the valve closed. Application 2022, 2025, 2027, 2122, 2125, 2127.

Damper Status Operation

When using an AZM it is possible, after a period of operation, for the calculated damper position to differ from the actual (physical) damper position.

If this occurs, the controller will *automatically* compensate for any difference by readjusting the calculated damper position. This calculated position may not match the actual position.

Fail-safe Operation

If the AVS fails, the controller uses pressure dependent control. The temperature loop controls the operation of the damper.

If the RTS fails, then the controller operates using the last known temperature value.

Secure Mode Operation

The Terminal Box Controller—Electronic Output with Secure Mode, product number 540-100C, has Secure Mode. When Secure Mode is enabled, any attempts to make point changes in the TEC will be rejected and result in an error message indicating that the priority is too low. This mode can only be enabled/disabled through the Insight workstation

Heating and Cooling Switchover

The heating/cooling switchover determines whether the controller is in heating or cooling mode by monitoring the room temperature and the demand for heating and cooling (as determined by the temperature control loops).

Modulate Damper During Heating Mode (optional)

Applications that have a heating source (valve/electric) can be configured to modulate the flow setpoint in sequence with the heating source.



CAUTION:

If the damper is set to modulate in heating mode, make sure the controller is in the appropriate mode for the current supply air temperature.

Hot Water Reheat



CAUTION:

Do not set HTG FLOW MIN (Point 33) to 0 cfm (0 lps). A minimum airflow should be provided across the heating coils when the heating valve is open.

When the controller is in cooling mode, the heating valve(s) are closed.

The heating loop modulates the heating valve(s) to warm up the room. In cooling mode, the heating valve is closed.

Electric Reheat



CAUTION:

Verify that the equipment is supplied with safeties by others to ensure that there is airflow across the heating coils when they are to be energized.

The heating loop controls up to three stages of electric reheat to warm up the room. The electric reheat is time modulated using a duty cycle. When the controller is in cooling mode, the electric heat is OFF at all times.

Notes

1. If the temperature swings in the room are excessive or if there is trouble in maintaining the setpoint, contact your local Siemens Building Technologies, Inc. representative for more information.
2. The Terminal Box Controller — Electronic Output, as shipped from the factory, keeps all associated equipment OFF. The controller and its equipment are released to application control at start-up.

Application 2020/2120 VAV Cooling Only

Overview

In Application 2020 and 2120, the controller modulates the supply air damper of the terminal box for cooling. In order for it to work properly, the central air-handling unit must provide cool supply air. See Figure 2- 1.

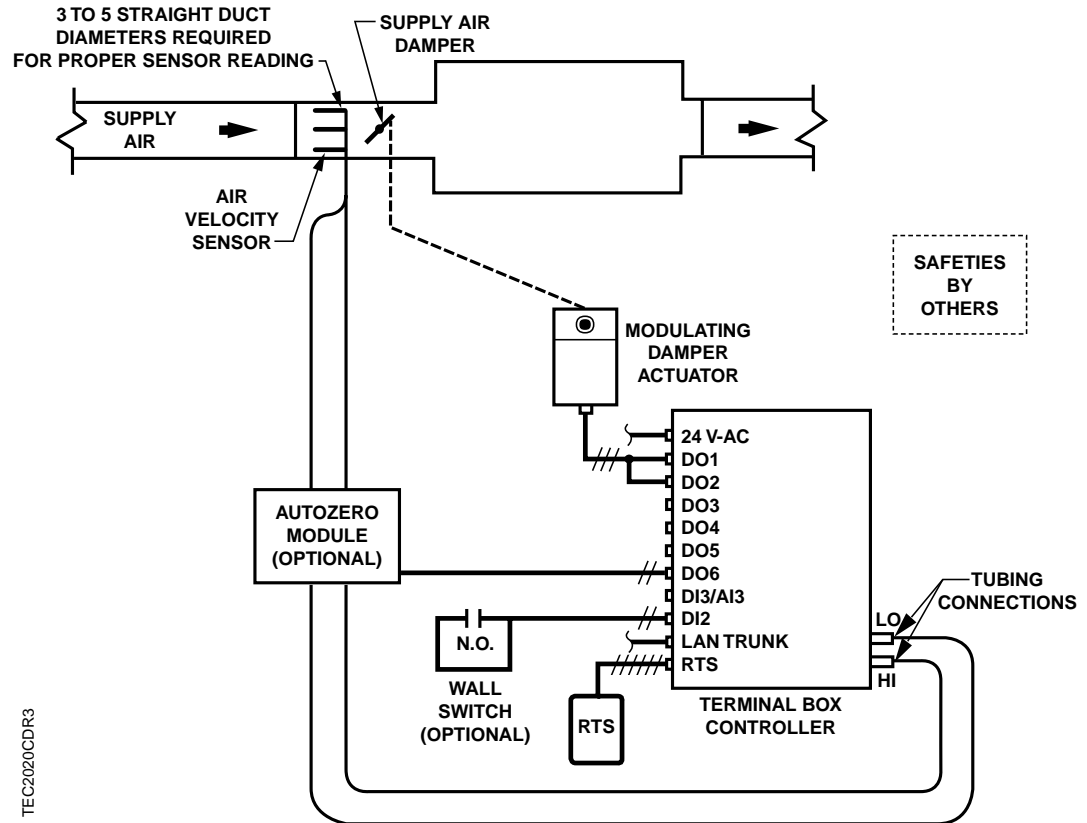

Figure 2- 1. Application 2020 and 2120 Control Drawing.

Application 2021/2121 VAV Cooling or Heating

Overview

In Application 2021 and 2121, the controller modulates the supply air damper of the terminal box for cooling and heating. In order for it to work properly, the central air-handling unit must provide cool supply air in cooling mode and warm air in heating mode. See Figure 2- 2.

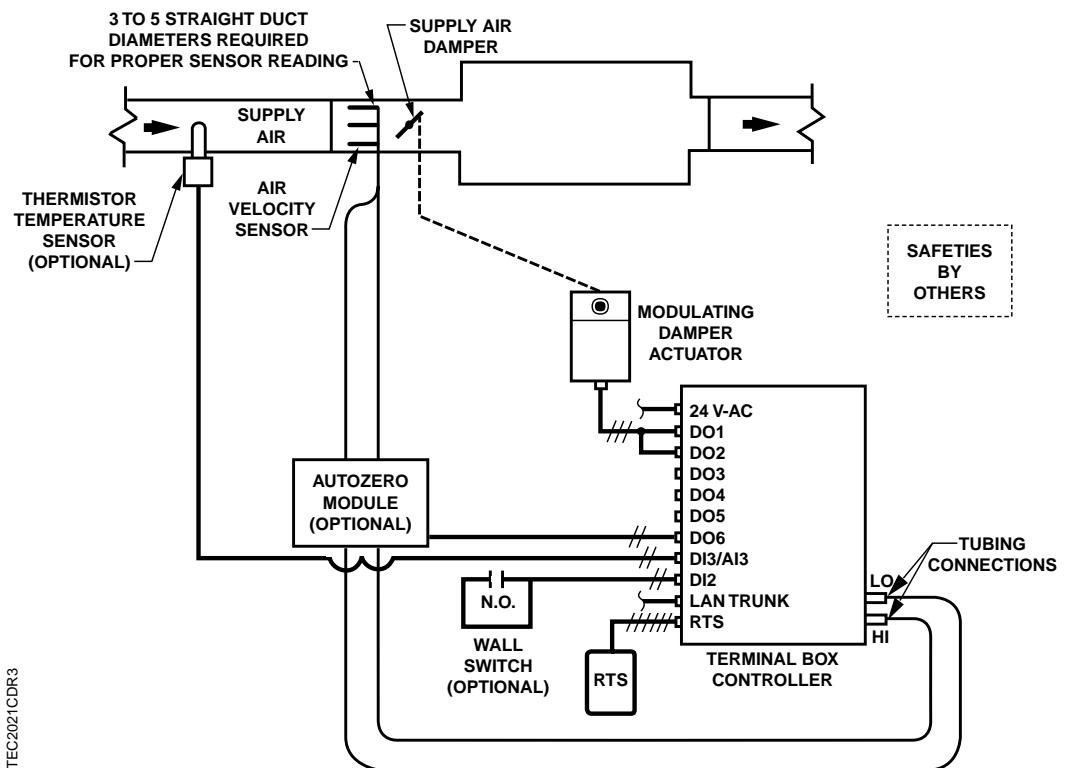

Figure 2- 2. Application 2021 and 2121 Control Drawing.

TEC2021CDR3

Application 2022/2122 VAV with Electric Reheat or Baseboard Radiation

Overview

In Application 2022 and 2122, the controller modulates the supply air damper for the terminal box for cooling and controls stages of electric reheat or baseboard radiation for heating. When in heating, the terminal box either maintains minimum airflow or modulates the supply air damper. In order for the terminal box to work properly, the central air-handling unit must provide supply air. See Figure 2-3 and Figure 2-4.

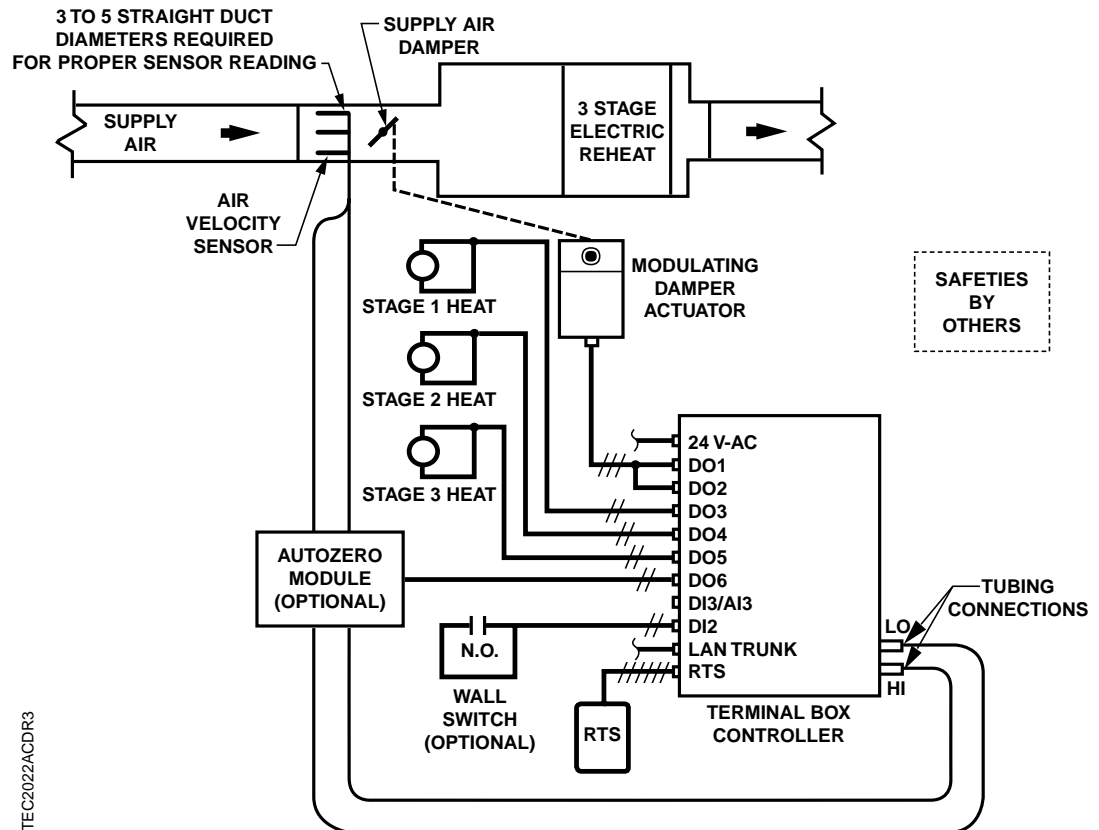

Figure 2-3. Application 2022 and 2122 Control Drawing for Electric Reheat.

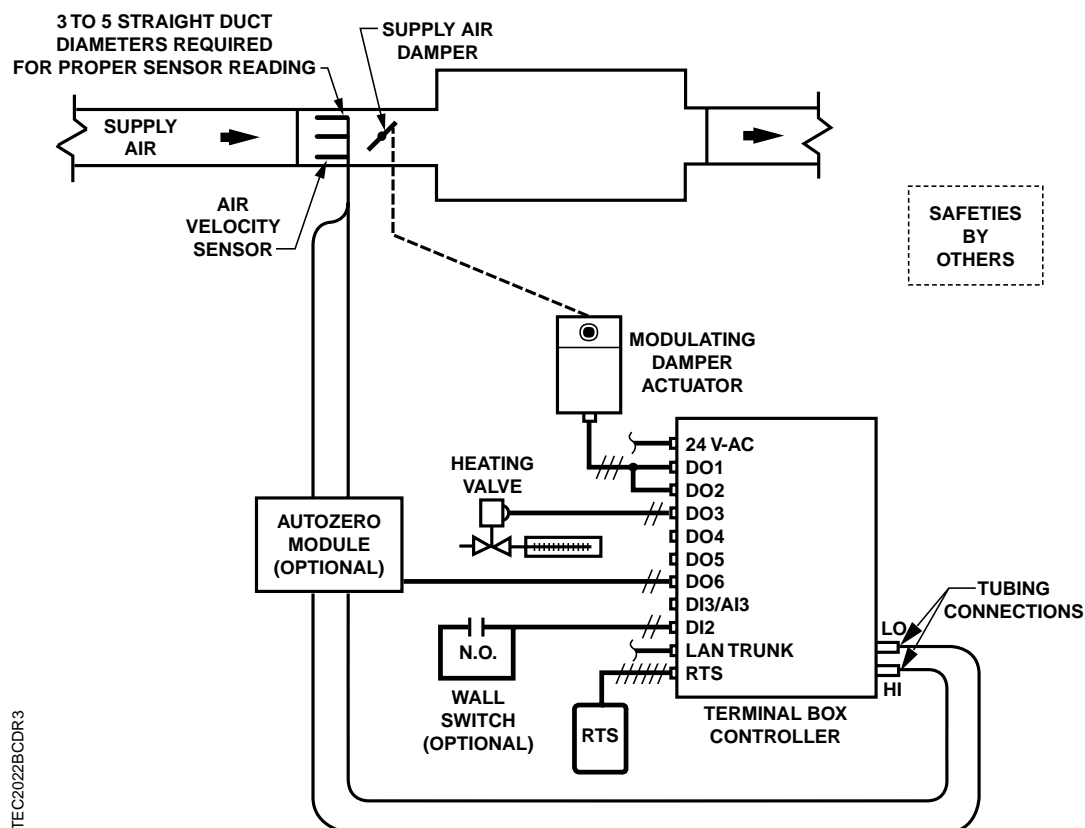

Figure 2-4. Application 2022 and 2122 Control Drawing for Baseboard Radiation.

Baseboard Radiation

Baseboard radiation can be a two-position valve or electrical resistance heating.

If the controller is in cooling mode, the heating valve is closed. When in heating mode, the controller will operate the heating valve to maintain the heating setpoint.

Electric Heat Interlock

The electric heat stages will be disabled (turned off) when the electric heat airflow is less than the defined minimum.



CAUTION:

Do not set EHEAT FLOW (the defined minimum) to less than 5%, otherwise the electric heat interlock will be disabled.

Application 2023/2123 VAV with Hot Water Reheat

Overview

In Application 2023 and 2123, the controller modulates the supply air damper of the terminal box for cooling and modulates a reheat valve (or valves) for heating. When in heating, the terminal box either maintains minimum airflow or modulates the supply air damper. In order for the terminal box to work properly, the central air handling unit must provide supply air. See Figure 2-5.

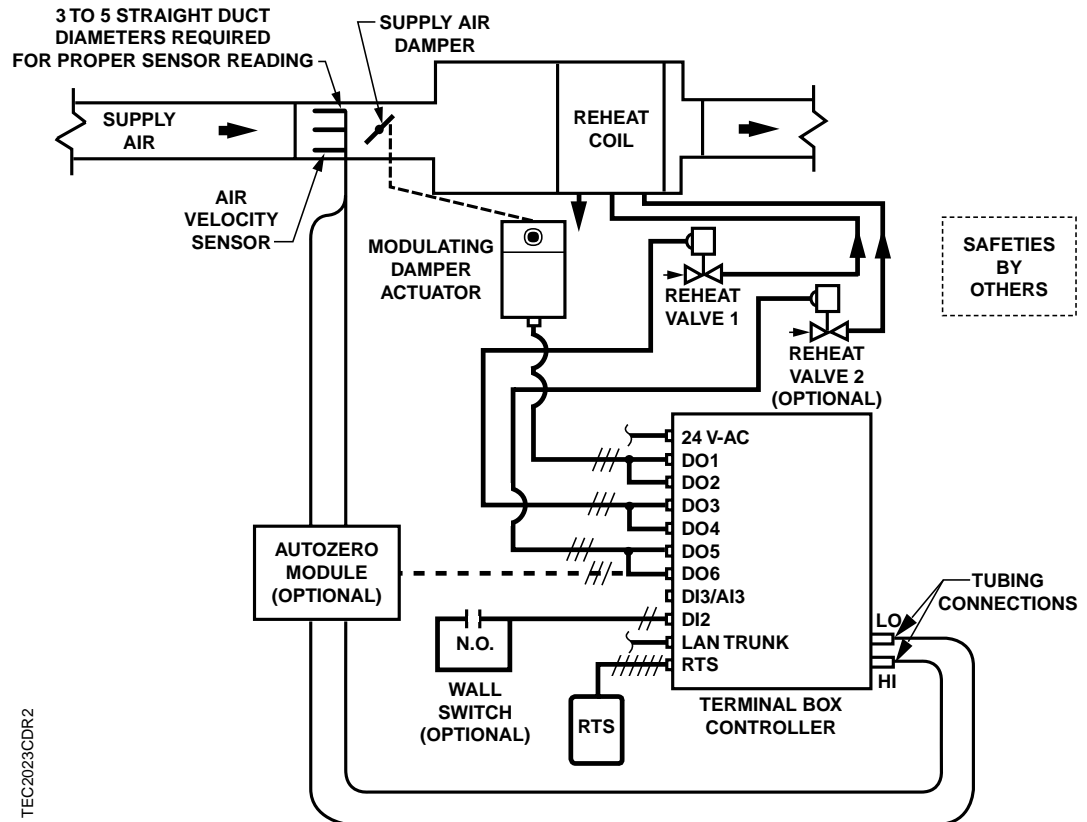

Figure 2-5. Application 2023 and 2123 Control Drawing.

TEC2023CDR2

Application 2024/2124 VAV Series Fan Powered with Electric Reheat

Overview

In Application 2024 and 2124, the controller modulates the supply air damper of the terminal box for cooling and controls stages of electric reheat for heating. When in heating, the terminal box either maintains minimum airflow or modulates the supply air damper. The terminal box also has a series fan for air circulation. In order for the terminal box to work properly, the central air-handling unit must provide supply air. See Figure 2-6.

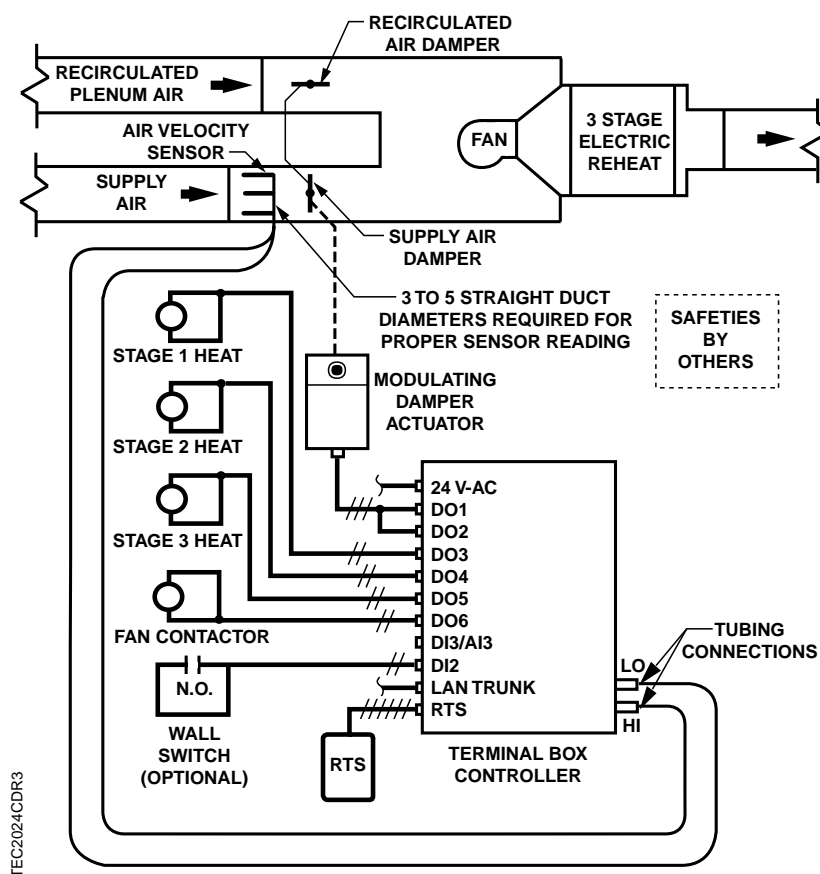

Figure 2-6. Application 2024 and 2124 Control Drawing.

Fan Operation



CAUTION:

On series fan powered terminal boxes, the terminal box fan must be controlled/interlocked to start either before or at the same time as the central air handler. Failure to do so may cause the terminal box fan to rotate backwards and cause consequent damage at start up.

In day mode, the fan is ON all the time.

In night mode, the fan cycles on when heating or cooling is required.

Application 2025/2125 VAV Series Fan Powered with Hot Water Reheat

Overview

In Application 2025 and 2125, the controller modulates the supply air damper of the terminal box for cooling and modulates a hot water valve for heating. When in heating, the terminal box either maintains minimum airflow or modulates the supply air damper. The terminal box also has a series fan for air circulation. In order for the terminal box to work properly, the central air handling unit must provide supply air. See Figure 2-7.

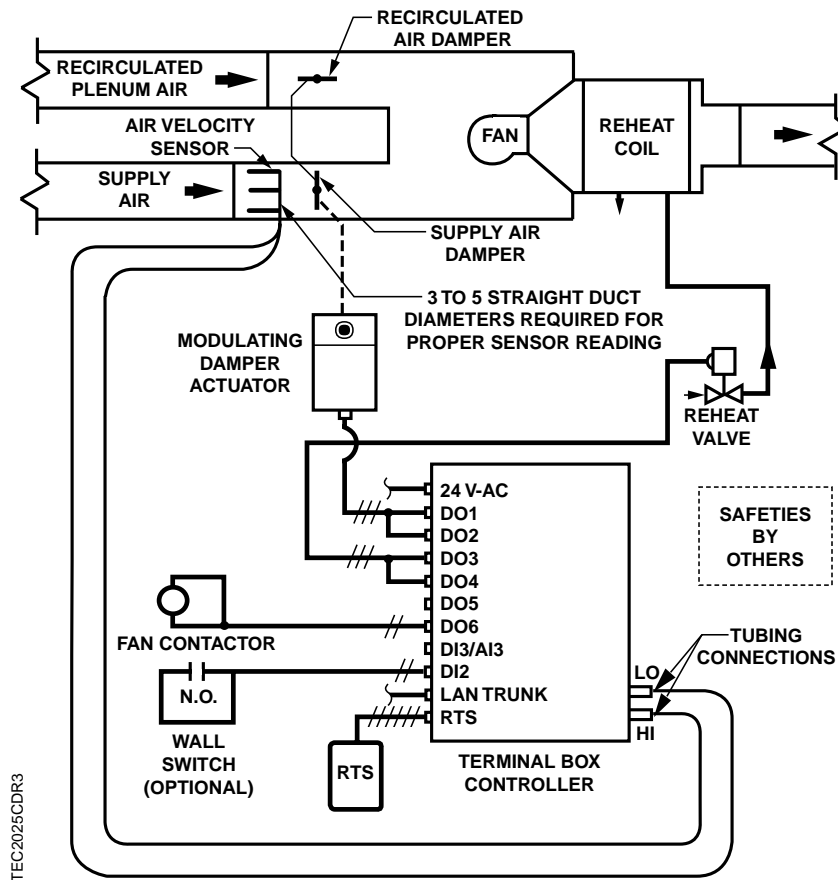

Figure 2-7. Application 2025 and 2125 Control Drawing.

Fan Operation



CAUTION:

On series fan powered terminal boxes, the terminal box fan must be controlled/interlocked to start either before or at the same time as the central air handler. Failure to do so may cause the terminal box fan to rotate backwards and cause consequent damage at start up.

In day mode, the fan is ON all of the time.

In night mode, the fan is cycles on when heating or cooling is required.

Application 2026/2126 VAV Parallel Fan Powered with Electric Reheat

Overview

In Application 2026 and 2126, the controller modulates the supply air damper of the terminal box for cooling and controls stages of electric reheat for heating. When in heating, the terminal box either maintains minimum airflow or modulates the supply air damper. The terminal box also has a parallel fan, which recirculates the room air. In order for the terminal box to work properly, the central air handling unit must provide supply air. See Figure 2-8.

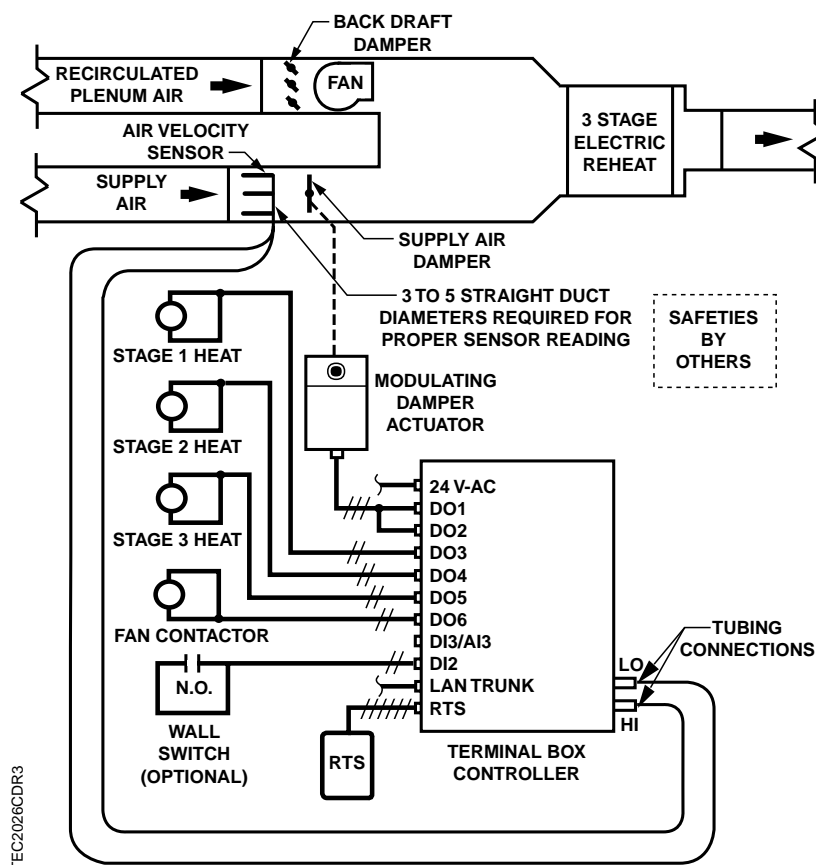

Figure 2-8. Application 2026 and 2126 Control Drawing.

Fan Operation

The fan turns on when heating is required.

Application 2027/2127 VAV Parallel Fan Powered with Hot Water Reheat

Overview

In Application 2027 and 2127, the controller modulates the supply air damper of the terminal box to provide for cooling and modulates a hot water valve for heating. When in heating, the terminal box either maintains minimum airflow or modulates the supply air damper. The terminal box also has a parallel fan that recirculates the room air. In order for the terminal box to work properly, the central air handling unit must provide supply air. See Figure 2-9.

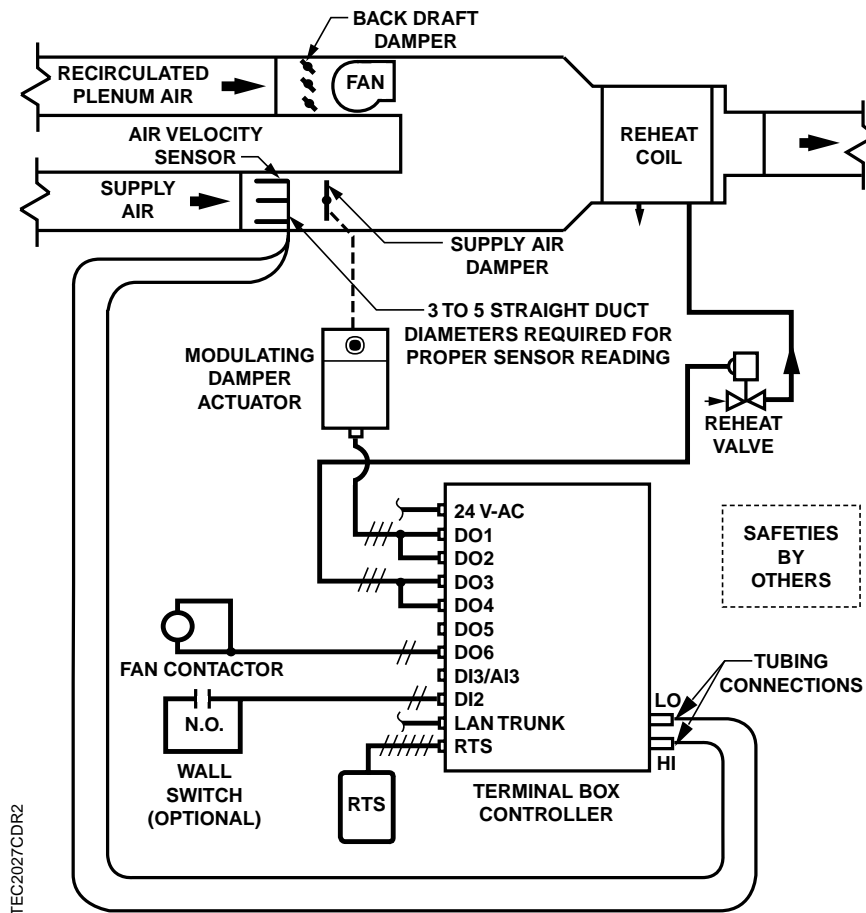

Figure 2-9. Application 2027 and 2127 Control Drawing.

Fan Operation

The fan turns on when heating is required.

Application 2091/2191 Slave Mode

Overview

Application 2091 and 2191 are the slave mode applications for the Terminal Box Controller — Electronic Output (P/N 540-100 and 540-100C). Slave mode is the default application that comes up when power is first applied to the controller. Slave mode provides no control. Its purpose is to allow the operator to perform equipment checkout before a control application is put into effect and to set some basic controller parameters (CTRL ADDRESS, APPLICATION, etc.). A controller in default state can also be used as a point extension device by unbundling spare I/O points at the field panel.

Using Auxiliary Points

It is possible to have extra points available on a Terminal Box Controller — Electronic Output in addition to the ones used by the current application that is running in the controller. If these extra points are to be controlled by a field panel, then they must be unbundled at the field panel.

Using the Controller as a Point Extension Device

If the controller is only used as a point extension device, with no control application in affect, its application must be set to slave mode and points must be unbundled at the field panel. All points must be controlled from the field panel in order to be used.

DO 1, DO 2, DO 3, DO 4, DO 5, and DO 6 may be used as separate DOs or in pairs (DO 1 and DO 2, DO 3 and DO 4, DO 5 and DO 6) to control a motor as shown in the example.

NOTE: If using either a motor or DOs as auxiliary points, be sure to set MTR SETUP (Point 58) to the correct value. If using a pair of DOs to control a motor, then the DOs cannot be unbundled. Only s MTR1 COMD (Point 48) and MTR2 COMD (Point 52) can be unbundled to control the motors.

Example

If using DO 1 and DO 2 as the physical terminations for a motor, follow these steps:

1. Set MTR SETUP to 1 to enable the motor.
2. Unbundle MTR1 COMD at the field panel to command the motor from the field panel.

Contact your local Siemens Building Technologies, Inc. representative for other combinations of DOs and motors.

3

Point Database

Overview

Chapter 3 presents a description of the Terminal Box Controller — Electronic Output point database, including point descriptors, point addresses, and a listing of applications in which each point is found.

Descriptor	Address ¹	Application	Description	Slope ² (SI Units)	Intercept (SI Units)
CTLR ADDRESS	01	All	Identifies the controller on the FLN trunk.	1.000	0.000
APPLICATION	02	All	Identification number of the program running in the controller.	1.000	0.000
RMTMP OFFSET	03	2120, 2121 2122, 2123 2124, 2125 2126, 2127 2191	Compensates for deviations between the value of ROOM TEMP (Point 4) and the actual room temperature. This corrected value is displayed in CTL TEMP (Point 78). RMTMP OFFSET + ROOM TEMP = CTL TEMP	0.250 (0.140)	-31.75 (-17.78)
ROOM TEMP	{04} ³	All	Actual reading from the room temperature sensor.	0.250 (0.140)	48.000 (8.889)
HEAT.COOL	{05}	All <i>except</i> 2020, 2120 2091, 2191	Current mode of operation for applications that can be in either a heating mode or a cooling mode.	–	–

1. Points not listed are not used in this application.
2. A single value in a column means that the value is the same in English units and in SI units.
3. Point numbers that appear in brackets { } may be unbundled at the field panel.

Continued on next page...

Descriptor	Address ¹	Application	Description	Slope ² (SI Units)	Intercept (SI Units)
DAY CLG STPT	06	All <i>except</i> 2091, 2191	The temperature setpoint in degrees that the controller maintains during day periods in cooling mode if a room temperature sensor setpoint dial is not present or is not used. See STPT DIAL (Point 14).	0.250 (0.140)	48.000 (8.889)
NGT CLG STPT	08	All <i>except</i> 2091, 2191	The temperature setpoint in degrees that the controller maintains during the night periods in cooling mode.	0.250 (0.140)	48.000 (8.889)
DAY HTG STPT	07	All <i>except</i> 2020, 2120 2091, 2191	The temperature setpoint in degrees that the controller maintains during day periods in heating mode if a room temperature sensor setpoint dial is not present or is not used. See STPT DIAL (Point 14).	0.250 (0.140)	48.000 (8.889)
NGT HTG STPT	09	All <i>except</i> 2020, 2120 2091, 2191	The temperature setpoint in degrees that the controller maintains during the night periods in heating mode.	0.250 (0.140)	48.000 (8.889)
RM STPT MIN	11	All <i>except</i> 2091, 2191	The minimum temperature setpoint in degrees that the controller can use from the setpoint dial. This overrides any temperature setpoint from the setpoint dial that falls below this minimum.	0.250 (0.140)	48.000 (8.889)
RM STPT MAX	12	All <i>except</i> 2091, 2191	The maximum temperature setpoint in degrees that the controller can use from the setpoint dial. This overrides any temperature setpoint from the setpoint dial that falls above this maximum.	0.250 (0.140)	48.000 (8.889)

1. Points not listed are not used in this application.
2. A single value in a column means that the value is the same in English units and in SI units.
3. Point numbers that appear in brackets { } may be unbundled at the field panel.

Continued on next page...

Descriptor	Address ¹	Application	Description	Slope ² (SI Units)	Intercept (SI Units)
RM STPT DIAL	{13} ³	All	The temperature setpoint in degrees from the room temperature sensor (not available on all temperature sensor models). This setpoint will be used for control in day mode (heating or cooling) when enabled by STPT DIAL (Point 14).	0.250 (0.140)	48.000 (8.889)
STPT DIAL	14	All <i>except</i> 2091, 2191	YES indicates that there is a room setpoint dial on the room temperature sensor and it should be used as the temperature setpoint for control in day/occupied mode. NO indicates that the appropriate preset setpoint (Point 6, 7, 8, 9, or 10) will be used as the temperature setpoint for control in day/occupied heating or cooling mode. Valid input: YES or NO.	–	–
AUX TEMP	{15}	All <i>except</i> 2021, 2121	Actual reading from a 100K Ω thermistor connected to the controller's AI 3 input. When a thermistor is connected at AI 3, DI 3 is not available. See DI 3 (Point 25).	0.500 (0.280)	37.500 (3.056)
SUPPLY TEMP	{15}	2021, 2121	Actual reading from a 100K Ω thermistor connected to the controller's AI 3 input. The controller uses this value to determine whether it is in heating or cooling mode.	0.500 (0.280)	37.500 (3.056)
FLOW START	16	All <i>except</i> 2020, 2120 2021, 2121 2091, 2191	Determines how the damper modulation will be sequenced while in heating mode. When HTG LOOPOUT (Point 80) is above this value, then FLOW STPT (Point 93) starts to increase.	0.400	0.000

1. Points not listed are not used in this application.
2. A single value in a column means that the value is the same in English units and in SI units.
3. Point numbers that appear in brackets { } may be unbundled at the field panel.

Continued on next page...

Descriptor	Address ¹	Application	Description	Slope ² (SI Units)	Intercept (SI Units)
FLOW END	17	All except 2020, 2120, 2021, 2121, 2091, 2191	Determines how the damper modulation will be sequenced while in heating mode. When HTG LOOPOUT (Point 80) is below this value, then FLOW STPT (Point 93) starts to decrease.	0.400	0.000
WALL SWITCH	18	All	YES indicates that the controller is to monitor the status of a wall switch that is connected to DI 2. NO indicates that the controller will not monitor the status of a wall switch, even if one is connected. Valid input: YES or NO.	–	–
DI OVRD SW	{19} ³	All	Actual indication of the status of the override switch (not physically available on all temperature sensor models) at the room temperature sensor. ON indicates that the switch is being pressed. OFF indicates that the switch is released. Valid input: ON or OFF.	–	–
OVRD TIME	20	All except 2091, 2191	The amount of time in hours that the controller will operate in day/occupied mode when the override switch is pressed while the controller is in night/unoccupied mode.	1.000	0.000

1. Points not listed are not used in this application.
2. A single value in a column means that the value is the same in English units and in SI units.
3. Point numbers that appear in brackets { } may be unbundled at the field panel.

Continued on next page...

Descriptor	Address ¹	Application	Description	Slope ² (SI Units)	Intercept (SI Units)
NGT OVRD	{21} ³	All except 2091, 2191	Indicates the mode that the controller is operating in with respect to the override switch. NIGHT indicates that the switch has not been pressed and the override timer is not active. DAY indicates that the switch has been pressed and the override timer is active. The controller then uses a day mode temperature setpoint. This point is only in effect when DAY.NGT (Point 29) indicates night mode.	–	–
REHEAT START	22	All except 2020, 2120 2021, 2121 2091, 2191	Determines how the reheat modulation will be sequenced while in heating mode. When HTG LOOPOUT (Point 80) is above this value, then the reheat modulates upward.	0.400	0.000
REHEAT END	23	All except 2020, 2120 2021, 2121 2091, 2191	Determines how the reheat modulation will be sequenced while in heating mode. When HTG LOOPOUT (Point 80) is below this value, then the reheat modulates downward.	0.400	0.000
DI 2	{24}	All	Actual status of a contact connected to the controller at DI 2. ON indicates that the contact is closed; OFF indicates that the contact is open. If a wall switch is used, it is connected to DI 2. See WALL SWITCH (Point 18).	–	–

1. Points not listed are not used in this application.
2. A single value in a column means that the value is the same in English units and in SI units.
3. Point numbers that appear in brackets { } may be unbundled at the field panel.

Continued on next page...

Descriptor	Address ¹	Application	Description	Slope ² (SI Units)	Intercept (SI Units)
DI 3	{25} ³	All except 2021, 2121	Actual status of a contact connected to the controller at AI 3/DI 3. ON indicates that the contact is closed; OFF indicates that the contact is open. When a contact is connected at DI 3, AI 3 is not available. See AUX TEMP (Point 15).	–	–
SERIES ON	26	2024, 2124 2025, 2125	When flow rises above this value, the series fan will turn ON.	0.400	0.000
SERIES ON	26	2026, 2126	This point is present, but not used in this application.	0.400	0.000
SERIES OFF	27	2024, 2124, 2025, 2125	When flow drops below this value and the other condition has been met, the series fan will turn OFF.	0.400	0.000
SERIES OFF	27	2026, 2126	This point is present, but not used in this application.	0.400	0.000
PARALLEL ON	28	2024, 2124	This point is present, but not used in this application.	0.400	0.000
PARALLEL ON	28	2026, 2126, 2027, 2127	When flow drops below this value and the other condition has been met, the parallel fan will turn ON.	0.400	0.000
DAY.NGT	{29}	All	Indicates the mode in which the controller is operating. Day temperature setpoints will be used in day mode. Night temperature setpoints will be used in night mode. This point is normally set by the field panel.	–	–
PARALLEL OFF	30	2024, 2124	This point is present, but not used in this application.	0.400	0.000
PARALLEL OFF	30	2026, 2126 2027, 2127	When flow rises above this value, the parallel fan will turn OFF.	0.400	0.000

1. Points not listed are not used in this application.
2. A single value in a column means that the value is the same in English units and in SI units.
3. Point numbers that appear in brackets { } may be unbundled at the field panel.

Continued on next page...

Descriptor	Address ¹	Application	Description	Slope ² (SI Units)	Intercept (SI Units)
CLG FLOW MIN	31	All <i>except</i> 2091, 2191	The minimum amount of air in CFM (LPS) to be supplied to the space in cooling mode.	4.000 (1.888)	0.000
CLG FLOW MAX	32	All <i>except</i> 2091, 2191	The maximum amount of air in CFM (LPS) to be supplied to the space in cooling mode.	4.000 (1.888)	0.000
HTG FLOW MIN	33	All <i>except</i> 2020, 2120 2091, 2191	The minimum amount of air in CFM (LPS) to be supplied to the space in heating mode.	4.000 (1.888)	0.000
HTG FLOW MAX	34	All <i>except</i> 2020, 2120 2091, 2191	The maximum amount of air in CFM (LPS) to be supplied to the space in heating mode.	4.000 (1.888)	0.000
AIR VOLUME	{35} ³	All	Actual amount of air in CFM (LPS) currently passing through the air velocity sensor.	4.000 (1.888)	0.000
FLOW COEFF	36	All	Calibration factor for the airflow sensor.	0.010	0.000
MTR3 COMD	{37}	2020, 2120 2021, 2121 2022, 2122 2091, 2191	The value to which the Motor 3 actuator is commanded in percent of full value.	0.400	0.000
VLV2 COMD	{37}	2023, 2123	The value to which the valve 2 actuator is commanded in percent of full travel for applications using a second water valve.	0.400	0.000
MTR3 POS	{38}	2020, 2120 2021, 2121 2022, 2122 2091, 2191	The current position of the Motor 3 actuator in percent of full travel. This value is calculated based on motor run time.	0.400	0.000
VLV2 POS	{38}	2023, 2123	The current position of Valve 2 in percent of full travel. This value is calculated based on valve run time.	0.400	0.000
MTR3 TIMING	39	All <i>except</i> 2024, 2124 2025, 2125 2026, 2126 2027, 2127	The time required for the Motor 3 actuator to travel from the full closed position to the full open position.	1.000	0.000

1. Points not listed are not used in this application.
2. A single value in a column means that the value is the same in English units and in SI units.
3. Point numbers that appear in brackets { } may be unbundled at the field panel.

Continued on next page...

Descriptor	Address ¹	Application	Description	Slope ² (SI Units)	Intercept (SI Units)
DO 1	{41} ³	All	Digital output 1 controls a 24 Vac load with an ON or OFF status. If Motor 1 is enabled, DO 1 is coupled with DO 2 to control an actuator.	–	–
DO 2	{42}	All	Digital output 2 controls a 24 Vac load with an ON or OFF status. If Motor 1 is enabled, DO 2 is coupled with DO 1 to control an actuator.	–	–
DO 3	{43}	All except 2022, 2122 2024, 2124 2026, 2126	Digital output 3 controls a 24 Vac load with an ON or OFF status. If Motor 2 is enabled, DO 3 is coupled with DO 4 to control an actuator.	–	–
HEAT STAGE 1	{43}	2022, 2122 2024, 2124 2026, 2126	This point is DO 3 in applications with electric reheat. This digital output controls the contact for the first stage of heating and has a status of ON or OFF.	–	–
DO 4	{44}	All except 2022, 2122 2024, 2124 2026, 2126	Digital output 4 controls a 24 Vac load with an ON or OFF status. If Motor 2 is enabled, DO 4 is coupled with DO 3 to control an actuator.	–	–
HEAT STAGE 2	{44}	2022, 2122 2024, 2124 2026, 2126	This point is DO 4 in applications with electric reheat. This digital output controls the contact for the second stage of heating and has a status of ON or OFF.	–	–
DO 5	{45}	2020, 2120 2021, 2121 2023, 2123 2091, 2191	Digital output 5 controls a 24 Vac load with an ON or OFF status. If Motor 3 is enabled, DO 5 is coupled with DO 6 to control an actuator.	–	–
DO 5	{45}	2025, 2125 2027, 2127	Digital output 5 controls a 24 Vac load with an ON or OFF status.	–	–

1. Points not listed are not used in this application.
2. A single value in a column means that the value is the same in English units and in SI units.
3. Point numbers that appear in brackets { } may be unbundled at the field panel.

Continued on next page...

Descriptor	Address ¹	Application	Description	Slope ² (SI Units)	Intercept (SI Units)
HEAT STAGE 3	{45} ³	2022, 2122 2024, 2124 2026, 2126	This point is a digital output used to control the contact for the third stage of heating and has a status of ON or OFF.	–	–
DO 6	{46}	All except 2024, 2124 2025, 2125 2026, 2126 2027, 2127	Digital output 6 controls a 24 Vac load with an ON or OFF status. If Motor 3 is enabled, DO 6 is coupled with DO 5 to control an actuator. In applications with CAL MODULE (Point 87) set to YES, this digital output controls the Autozero Module to calibrate the controller's internal air velocity transducer.	–	–
FAN	{46}	2024, 2124 2025, 2125 2026, 2126 2027, 2127	This point is a digital output used to control the fan. ON indicates that the DO is energized; OFF indicates that the DO is de-energized.	–	–
DMPR COMD	{48}	All except 2091, 2191	The value to which the damper motor is commanded in percent of full travel.	0.400	0.000
MTR1 COMD	{48}	2091, 2191	The value to which the Motor 1 actuator is commanded in percent of full travel.	0.400	0.000
DMPR POS	{49}	All except 2091, 2191	The current position of the damper motor in percent of full travel. This value is calculated based on motor run time.	0.400	0.000
MTR1 POS	{49}	2091, 2191	The current position of the damper motor in percent of full travel. This value is calculated based on motor run time. See MTR1 TIMING (Point 51).	0.400	0.000
MTR1 TIMING	51	All	The time required for the Motor 1 actuator to travel from full closed to the full open position.	1.000	0.000

1. Points not listed are not used in this application.
2. A single value in a column means that the value is the same in English units and in SI units.
3. Point numbers that appear in brackets { } may be unbundled at the field panel.

Continued on next page...

Descriptor	Address ¹	Application	Description	Slope ² (SI Units)	Intercept (SI Units)
MTR2 COMD	{52} ³	2020, 2120 2021, 2121 2091, 2191	The value to which the Motor 2 actuator is commanded in percent of full travel (for use as an auxiliary slave point).	0.400	0.000
VLV COMD	{52}	2025, 2125 2027, 2127	The value to which the valve actuator is commanded in percent of full travel for applications using a water valve.	0.400	0.000
VLV1 COMD	{52}	2023, 2123	The value to which the valve 1 actuator is commanded in percent of full travel for applications using a water valve.	0.400	0.000
MTR2 POS	{53}	2020, 2120 2021, 2121 2091, 2191	The current position of the Motor 2 actuator in percent of full travel (for use as an auxiliary slave point). This value is calculated based on motor run time. See MTR2 TIMING (Point 55).	0.400	0.000
VLV POS	{53}	2025, 2125	The current position of the valve in percent of full travel for applications using a water valve. This value is calculated based on motor run time.	0.400	0.000
VLV1 POS	{53}	2023, 2123	The current position of valve 1 in percent of full travel for applications using a water valve. This value is calculated based on motor run time.	0.400	0.000
MTR2 TIMING	55	All <i>except</i> 2022, 2122 2024, 2124 2026, 2126	The time required for the Motor 2 actuator to travel from full closed to the full open position.	1.000	0.000
DMPR ROT ANG	56	All <i>except</i> 2091, 2191	The number of degrees the damper is free to travel.	1.000	0.000
DPR1 ROT ANG	56	2091, 2191	The number of degrees that damper 1 is free to travel.	1.000	0.000

1. Points not listed are not used in this application.
2. A single value in a column means that the value is the same in English units and in SI units.
3. Point numbers that appear in brackets { } may be unbundled at the field panel.

Continued on next page...

Descriptor	Address ¹	Application	Description	Slope ² (SI Units)	Intercept (SI Units)
DPR2 ROT ANG	57	2091, 2191	The number of degrees that damper 2 (damper 2, the hot duct damper, in Applications 30, 37, 67, and 69) is free to travel.	1.000	0.000
MTR SETUP	58	All	The configuration setup code for Motors 1, 2, and 3. This enables the motors individually and sets each motor to be either direct or reverse acting. Note: When a motor is enabled, its associated DOs are enabled.	1.000	0.000
DO DIR.REV	59	All	The configuration setup code for DOs. Allows the DOs to be direct or reverse acting (enabled equals energized or enabled equals de-energized).	1.000	0.000
EHEAT FLOW	60	2022, 2122	The flow required before the electric heat will be enabled.	0.400	0.000
COOL TEMP	61	2021, 2121	The discharge air temperature where the controller will switch from heating to cooling mode. Used only in applications with SUPPLY TEMP (Point 15).	0.500 (0.280)	37.500 (3.056)
HEAT TEMP	62	2021, 2121	The discharge air temperature where the controller will switch from cooling to heating mode. Used only in applications with SUPPLY TEMP (Point 15).	0.500 (0.280)	37.500 (3.056)
CLG P GAIN	63	All <i>except</i> 2091, 2191	The proportional gain value for the cooling temperature control loop.	0.250 (0.450)	0.000
CLG I GAIN	64	All <i>except</i> 2091, 2191	The integral gain value for the cooling temperature control loop.	0.001 (0.002)	0.000

1. Points not listed are not used in this application.
2. A single value in a column means that the value is the same in English units and in SI units.
3. Point numbers that appear in brackets { } may be unbundled at the field panel.

Continued on next page...

Descriptor	Address ¹	Application	Description	Slope ² (SI Units)	Intercept (SI Units)
CLG D GAIN	65	All <i>except</i> 2091, 2191	The derivative gain value for the cooling temperature control loop.	2.000 (3.600)	0.000
CLG BIAS	66	All <i>except</i> 2091, 2191	The biasing of the cooling temperature control loop. See CLG LOOPOUT (Point 79) or (Point 82) for Applications 137 to 138, 167 to 168.	0.400	0.000
HTG P GAIN	67	All <i>except</i> 2020, 2120 2091, 2191	The proportional gain value for the heating temperature control loop.	0.250 (0.450)	0.000
HTG I GAIN	68	All <i>except</i> 2020, 2120 2091, 2191	The integral gain value for the heating temperature control loop.	0.001 (0.002)	0.000
HTG D GAIN	69	All <i>except</i> 2020, 2120 2091, 2191	The derivative gain value for the heating temperature control loop.	2.000 (3.600)	0.000
HTG BIAS	70	All <i>except</i> 2020, 2120 2091, 2191	The biasing of the heating temperature control loop. See LOOPOUT (Point 80 or 81).	0.400	0.000
FLOW P GAIN	71	All <i>except</i> 2091, 2191	The proportional gain value for the flow control loop.	0.050	0.000
FLOW I GAIN	72	All <i>except</i> 2091, 2191	The integral gain value for the flow control loop.	0.001	0.000
FLOW D GAIN	73	All <i>except</i> 2091, 2191	The derivative gain value for the flow control loop.	2.000	0.000
FLOW BIAS	74	All <i>except</i> 2091, 2191	The biasing of the flow control loop.	0.400	0.000
FLOW	{75} ³	All <i>except</i> 2091, 2191	Indicates the actual amount of air currently passing the air velocity sensor. The value is calculated as a percentage based on where the value of AIR VOLUME (Point 35) is in the range between 0 and CTL FLOW MAX (Point 77).	0.250	0.000

1. Points not listed are not used in this application.
2. A single value in a column means that the value is the same in English units and in SI units.
3. Point numbers that appear in brackets { } may be unbundled at the field panel.

Continued on next page...

Descriptor	Address ¹	Application	Description	Slope ² (SI Units)	Intercept (SI Units)
CTL FLOW MIN	{76} ³	All <i>except</i> 2091, 2191	The active minimum flow used as a limit for the flow control loop. This value is the same as CLG FLOW MIN (Point 31) if the controller is in cooling mode, or is the same as HTG FLOW MIN (Point 33) if the controller is in heating mode, unless it is overridden.	4.000 (1.888)	0.000
CTL FLOW MAX	{77}	All <i>except</i> 2091, 2191	The active maximum flow used as a limit for the flow control loop. This value is the same as CLG FLOW MAX (Point 32) if the controller is in cooling mode, or is the same as HTG FLOW MAX (Point 34) if the controller is in heating mode unless, it is overridden.	4.000 (1.888)	0.000
CTL TEMP	{78}	All <i>except</i> 2091, 2191	The temperature used as input for the temperature control loops. This value is the same as the value in ROOM TEMP (Point 4) unless it is overridden.	0.250 (0.140)	48.000 (8.889)
CLG LOOPOUT	{79}	All <i>except</i> 2091, 2191	The cooling temperature control loop output value in percent.	0.400	0.000
HTG LOOPOUT	{80}	All <i>except</i> 2020, 2120 2091, 2191	The heating temperature control loop output value in percent.	0.400	0.000

1. Points not listed are not used in this application.
2. A single value in a column means that the value is the same in English units and in SI units.
3. Point numbers that appear in brackets { } may be unbundled at the field panel.

Continued on next page...

Descriptor	Address ¹	Application	Description	Slope ² (SI Units)	Intercept (SI Units)
AVG HEAT OUT	{81} ³	2022, 2024 2026	This point is used to determine what stages of electric heat are used for a given loop output value. The ranges for the value are determined by the number of stages used: 0 to 100 for 1 stage of electric heat, 0 to 200 for 2 stages of electric heat, and 0 to 300 for 3 stages of electric heat. In Applications 22, 24, 26, 32, 35-38, 52, and 54 with electric heat, this value is equal to: HTG LOOPOUT × STAGE COUNT.	2.000	0.000
AVG HEAT OUT	{81}	2122, 2124 2126	This point is used to determine what stages of electric heat are used for a given loop output value. The ranges for the value are determined by the number of stages used: 0 to 100 for 1 stage of electric heat, 0 to 200 for 2 stages of electric heat, and 0 to 300 for 3 stages of electric heat. In Applications 22, 24, 26, 32, 35-38, 52, and 54 with electric heat, this value is equal to: HTG LOOPOUT × STAGE COUNT.	0.400	0.0
STAGE MAX	82	2022, 2122 2024, 2124 2026, 2126	The value, in percent, which the heating loop must exceed for the electric heat to be ON for the full duty cycle (STAGE TIME, Point 89).	0.400	0.000
STAGE FAN	83	2025, 2125 2027, 2127	The valve must be opened greater than this value before the fan will turn ON.	0.400	0.000

1. Points not listed are not used in this application.
2. A single value in a column means that the value is the same in English units and in SI units.
3. Point numbers that appear in brackets { } may be unbundled at the field panel.

Continued on next page...

Descriptor	Address ¹	Application	Description	Slope ² (SI Units)	Intercept (SI Units)
STAGE MIN	83	2022, 2122 2024, 2124 2026, 2126	The value, in percent, which the heating loop must go below for the electric heat to be OFF for the full duty cycle (STAGE TIME, Point 89).	0.400	0.000
DMPR STATUS	{84} ³	2020, 2120 2021, 2121 2022, 2122 2023, 2123	This point is used only when CAL MODULE (Point 87) is set to YES. It readjusts the damper position if the command value is not equal to the actual position of the damper. CAL indicates that the damper is operating normally. RECAL indicates that the damper position was adjusted (recalibrated) by 25% because the desired airflow was not obtainable under its current status.	–	–
SWITCH LIMIT	85	All except 2020, 2120 2021, 2121 2091, 2191	The active temperature control loop output must be less than this value to switch between cooling mode and heating mode. Actual switchover depends on SWITCH DBAND (Point 90) being exceeded and is subject to SWITCH TIME (Point 86) being expired.	0.400	0.000
SWITCH TIME	86	All except 2020, 2120 2021, 2121 2091, 2191	The time, in minutes, before the heat/cool mode can change over when the other parameters are appropriate.	1.000	0.000

1. Points not listed are not used in this application.
2. A single value in a column means that the value is the same in English units and in SI units.
3. Point numbers that appear in brackets { } may be unbundled at the field panel.

Continued on next page...

Descriptor	Address ¹	Application	Description	Slope ² (SI Units)	Intercept (SI Units)
CAL MODULE	87	All <i>except</i> 2024, 2124 2025, 2125 2026, 2126 2027, 2127	YES indicates that the Autozero Modules are enabled to calibrate the air velocity transducers. The dampers will not be used for calibration. NO indicates that Autozero Modules are disabled and that the air velocity transducers will be calibrated by closing the dampers. Valid input: YES or NO.	–	–
STAGE COUNT	88	2022, 2122 2024, 2124 2026, 2126	The number of electric heating stages used by the application. DOs associated with unused stages may be used as spare DOs.	1.000	0.000
VALVE COUNT	88	2023, 2123	The number of heating valves available.	1.000	0.000
STAGE TIME	89	2022, 2122 2024, 2124 2026, 2126	The cycle time in minutes for the electric reheat stages. For example, if there are three stages of electric heat and STAGE TIME = 10 minutes, STAGE COUNT = 3, and AVG HEAT OUT = 150% then, Stage 1 is ON for 10 minutes (100% of the time), Stage 2 is ON for 5 minutes (50% of 10 minutes) and OFF for 5 minutes, and Stage 3 is OFF.	1.000	0.000

1. Points not listed are not used in this application.
2. A single value in a column means that the value is the same in English units and in SI units.
3. Point numbers that appear in brackets { } may be unbundled at the field panel.

Continued on next page...

Descriptor	Address ¹	Application	Description	Slope ² (SI Units)	Intercept (SI Units)
SWITCH DBAND	90	All except 2020, 2120 2021, 2121 2091, 2191	The temperature range in degrees which is compared to the difference between CTL TEMP (Point 78) and CTL STPT (Point 92). The difference must exceed this value for temperature control mode to change over. Changeover is also subject to the active temperature control loop output being below SWITCH LIMIT (Point 85) and SWITCH TIME (Point 86) being expired.	0.250 (0.140)	0.000
TOTAL VOLUME	{91} ³	All except 2091, 2191	The total amount of air delivered to a space in CF (L) since the last time the point was reset or rolled over.	4.000 (113)	0.000
CTL STPT	{92}	All except 2091, 2191	The actual setpoint value being used as input for the active temperature control loop.	0.250 (0.140)	48.000 (8.889)
FLOW STPT	{93}	All except 2091, 2191	The setpoint of the flow control loop.	0.250	0.000
CAL AIR	{94}	All	YES commands the controller to go through calibration sequence for the air velocity transducers. YES is also displayed when the calibration sequence is started automatically. CAL AIR automatically returns to NO after the calibration sequence is completed. Valid input: YES or NO.	–	–
CAL SETUP	95	All	The configuration setup code for the calibration sequence options.	1.000	0.000
CAL TIMER	96	All	Time interval, in hours, between the calibration sequence initiations if a timed calibration option is selected in CAL SETUP (Point 95).	1.000	0.000

1. Points not listed are not used in this application.
2. A single value in a column means that the value is the same in English units and in SI units.
3. Point numbers that appear in brackets { } may be unbundled at the field panel.

Continued on next page...

Descriptor	Address ¹	Application	Description	Slope ² (SI Units)	Intercept (SI Units)
DUCT AREA	97	All	Area, in square feet (square meters), of the duct where the air velocity sensor is located. This is a calculated value (calculated by the field panel or computer being used) that depends on duct shape and size. It is used in calculating all points in units of CFM, CF, LPS and L. Valid input: .025 ft ² (.002 m ²) through 6.375 ft ² (.5923 m ²).	0.025 (0.002)	0.000
LOOP TIME	98	All except 2091, 2191	The time, in seconds, between control loop calculations.	1.000	0.000
ERROR STATUS	{99} ³	All	The status code indicating any errors detected during controller power up. A status of 0 indicates there are no problems.	1.000	0.000

1. Points not listed are not used in this application.
2. A single value in a column means that the value is the same in English units and in SI units.
3. Point numbers that appear in brackets { } may be unbundled at the field panel.

4

Glossary

Overview

The glossary contains terms and acronyms that are used in this manual. For definitions of point database descriptors, see Chapter 3, *Point Database*, in this manual. For definitions of commonly used terms as well as acronyms and abbreviations associated with the APOGEE Automation System, see the *Technical Glossary of Building Controls Terminology and Acronyms* (125-2185). This book is available from your local Siemens Building Technologies, Inc. representative.

AI

Analog Input. Point that receives a signal that represents a condition which has more than two states. For example, flow rate sensors (water or air), temperature sensors (room or duct), pressure sensors (static or velocity), and humidity sensors (room, duct, or outdoor).

airflow

Rate at which a volume of air moves through a duct. Usually expressed in cubic feet per minute (cfm).

algorithm

Mathematical formula that uses varying inputs to calculate an output value.

AVS

Air Velocity Sensor.

AZM

Autozero Module. Terminal Equipment Controller (TEC) device used to calibrate the Constant Volume Controller's internal air velocity transducer without changing the volume of air being delivered to a space.

centralized control

Type of control offered by a controller that is connected by means of Floor Level Network (FLN) with an APOGEE field panel.

CFM

Cubic Feet per Minute.

control loop

PID algorithm that is used to control an output that is based on a setpoint and an input reading from a sensor.

DDC

Direct Digital Control.

DI

Digital Input. Physical input point that receives a two-state signal (ON/OFF, OPEN/CLOSED, YES/NO).

DO

Digital Output. Physical output point that sends a two-state signal (ON/OFF, OPEN/CLOSED, YES/NO).

English units

The foot-pound-second system of units for weights and measurements.

equipment controller

FLN device that provides additional point capacity to a field panel or provides individual room or mechanical equipment control.

field panel

A device containing a microprocessor for centralized control of system components and equipment controllers.

FLN

Floor Level Network. Formerly Local Area Network (LAN). Network consisting of Terminal Equipment Controller (TEC), Unitary Controllers (UC), fume hoods, etc.

intercept

Factor that converts analog values (used by the controller) to a form that the user can understand (engineering units).

LPS

Liters per Second.

loopout

Output of the control loop expressed as a percentage.

MMI

Man Machine Interface. Terminal and its interface program that allows you to communicate with a field panel or equipment controller.

override switch

Button on a room temperature sensor that an occupant can press to change the status of a room from unoccupied to occupied (or from night to day) for a predetermined time.

pressure independent

Variable Air Volume (VAV) room temperature control system in which the temperature drives an airflow setpoint.

PID

Proportional, Integral, Derivative.

RTS

Room Temperature Sensor.

setpoint

Virtual point that stores a point value such as a temperature setting. Points that monitor inputs, such as temperature, report actual values.

SI units

Système International d'Unités. The international metric system.

slave mode

Default application that displays when power is first applied to a Terminal Equipment Controller. No control action is initiated in the slave mode.

slope

Factor that converts analog values (used by the controller) to a form which the user can understand (engineering units).

stand-alone control

Type of control offered by a controller that is providing independent DDC control to a space.

Terminal Equipment Controller

Siemens Building Technologies, Inc. product family of equipment controllers (one is the Terminal Box Controller - Electronic Output) that house the applications software used to control terminal units, such as heat pumps, VAV terminal boxes, fan coil units, unit ventilators, etc.

unbundle

Term used to describe the entering of a point that resides in a controller's database into the field panel's database so that it can be monitored and controlled from the field panel.

VAV

Variable air volume. Ventilation system that changes the amount of air supplied to and exhausted from the rooms served.

Index

A

actuators	
1 st valve actuator	4
2 nd valve actuator	4
damper actuator	4
valve actuator	4
Air Velocity Sensor (AVS).....	2
algorithm	39
application 2020/2120	
control drawing	10
overview	10
application 2021/2121	
control drawing	11
overview	11
application 2022/2122	
baseboard radiation	1, 13
control drawing for baseboard radiation	13
control drawing for electric reheat	12
electric heat interlock	13
overview	12
application 2023/2123	
control drawing	14
overview	14
application 2024/2124	
control drawing	15
fan operation	15
overview	15
application 2025/2125	
control drawing	16
fan operation	16
overview	16
application 2026/2126	
control drawing	17
fan operation	17
overview	17
application 2027/2127	
control drawing	18
fan operation	18
overview	18
application 2091/2191	
overview	19
using auxiliary points	19
using controller as point extension device	
.....	19
applications	
calibration	7, 8, 27
control loops	7
control temperature setpoints	7
damper status operation	8
day/night mode	7
electric reheat	
stage 1	1, 9, 12, 15, 17
stage 2	1, 9, 12, 15, 17
stage 3	1, 9, 12, 15, 17
fail-safe operation	8
heating and cooling switchover	8
hot water reheat	1, 8, 14, 16, 18
modulate damper during heating mode ..	8
night mode override switch	7
notes	1, 9
secure mode operation	8
sequencing logic	7
centralized control	39
communication wiring	3
control loop	40
DDC	40
DI	40
Direct Digital Control (DDC).....	1, 7
DO	40
English units	40
equipment controller	40
fan	1, 3, 15, 16, 17, 18
FLN	40
Floor Level Network (FLN).....	3
hardware	
actuators	4
autozero module	3, 7
fan	1, 3, 15, 16, 17, 18
LEDs	4
power wiring	3
relay module	5
temperature sensors	4
loopout	40
override switch	41
PID	41
point database	
overview	21
power wiring	3
related equipment	5
relay module	5
RTS	41
secure mode operation	8
SI units	41
slope	41
stand-alone control	41
TEC	41
temperature sensors	
duct temperature sensor	4
RTS	4
Terminal Box Controller—Electronic Output	
ordering notes	1
product overview	1
related equipment	1

secure mode applications	1	2-position heating	3, 8, 27
standard applications	1	wiring	
temperature sensors	1	communication wiring.....	3
units, English	40	power wiring	3
valve			